



1995'ten günümüze

Cemil Gazel, 1995 yılında değirmen makinaları ve yan malzemeleri konusunda faaliyet göstermeye başlamıştır. Halen Gazel Makina olarak faaliyetini sürdürmektedir. Gazel Makina 7000 m² kapalı, 15000 m² açık alana sahip olup Çorum Organize Sanayi Bölgesi'nde yer almaktadır. Deneyimli kadrosu ile un fabrikaları kare elekleri ve yan malzemeleri konusunda uluslararası müşteri portföyüne sahiptir; Almanya başta olmak üzere birçok Avrupa, Asya ve Afrika ülkelerinin tamamına ihracat yapmaktadır.

Ayrıca Türkiye içerisinde çok sayıda değirmen makinası imalatı yapan firmalarla ortak çalışma içerisinde bulunmaktadır. Gelişmiş teknolojik üretim standartları izlenerek üretimi arttırmak ve yüksek kalite standartlarında üretim yapmak hedeflenmiştir. Üretim kalitesi doğrultusunda CE sertifikası bulunmaktadır.



HAKKIMIZDA ABOUT US



Cemil Gazel has started to produce milling machines and sub product 1995 and he established Gazel Milling factory has 7000 m² indoor area and 15000 m² open areas. In Corum industry zone Gazel Milling has got an experience staff and a wide customer portfolio of many European, Asian and African countries Especially France:

Also in Turkey a is in collaboration with a lot of companies that are producing milling machines. It has CE certificate as a demonstrate of production standards for increasing production and to produce at high standards.

gazel
m a k i n a

Çorum / Türkiye
00 90 364 2549630
www.gazelmakina.com

SIFER



Kalitesine inanmadığım
hiçbir ürünü almam,
satmam.

Ceo

CEMİL GAZEL

I do not buy or sell any products
that I do not believe it's quality.

NEDEN GAZEL?

- En iyi fiyata yüksek kalite
- Hızlı çözüm ve teslimat
- Sürekli müşteri memnuniyeti
- Müşteriye özel çözümler
- Sadece elek konusunda uzman kadro
- Yenilikçi anlayış
- Dünyanın farklı yerlerinde yıllardır çalışan 1000'in üzerinde elek



WHY GAZEL?

- Best price - high quality
- Fast production and delivery
- Continuous customer satisfaction
- Tailor made sifter for special areas
- Experience staff
- Continuously renovating
- More than 1000 working sifter all around the globe



SIFTER

gazel
milling



NOT ONLY THE PRODUCT, WE ALSO PRODUCE QUALITY



gazel
milling



İşin özünden ilham aldık
teknolojiyle harmanladık.

We were inspired by the essence of the work,
and combined it with technology.

SIEMENS





Our sifter consists of three parts. This provide great convenience white transporting and placing sifters in the factory.

Pressure shafts of sifter are placed at the top of the sections to make mantling and dismantling easy.

Weights, which provide oscillation movement of sifter, can be adjusted according to the desired working circle. More over, it weights can be easily added or removed if required.



Eleklerin üç parçadan oluşması, eleklerin nakliyesi ve fabrika içerisinde yerine ulaştırılmasında büyük kolaylık sağlamaktadır.

Elek baskı milleri sökülüp takılma kolaylığı ve daha randımanlı çalışması için dolap üstlerine yerleştirilmiştir.

Eleğin salınım hareketini sağlayan ağırlıklar eleğin çalıştığı çemberin çapını değiştirmek için ayarlanabilir. İstenirse ağırlık eklenip çıkarılabilir.

SİTİER



**YÜKSEK KAPASİTELİ
740 x 740 KASALI ELEK**

**HIGH CAPACITY SIFTER
WITH 740 x 740 SIEVES**

GMJ
Serisi
GMJ
Series

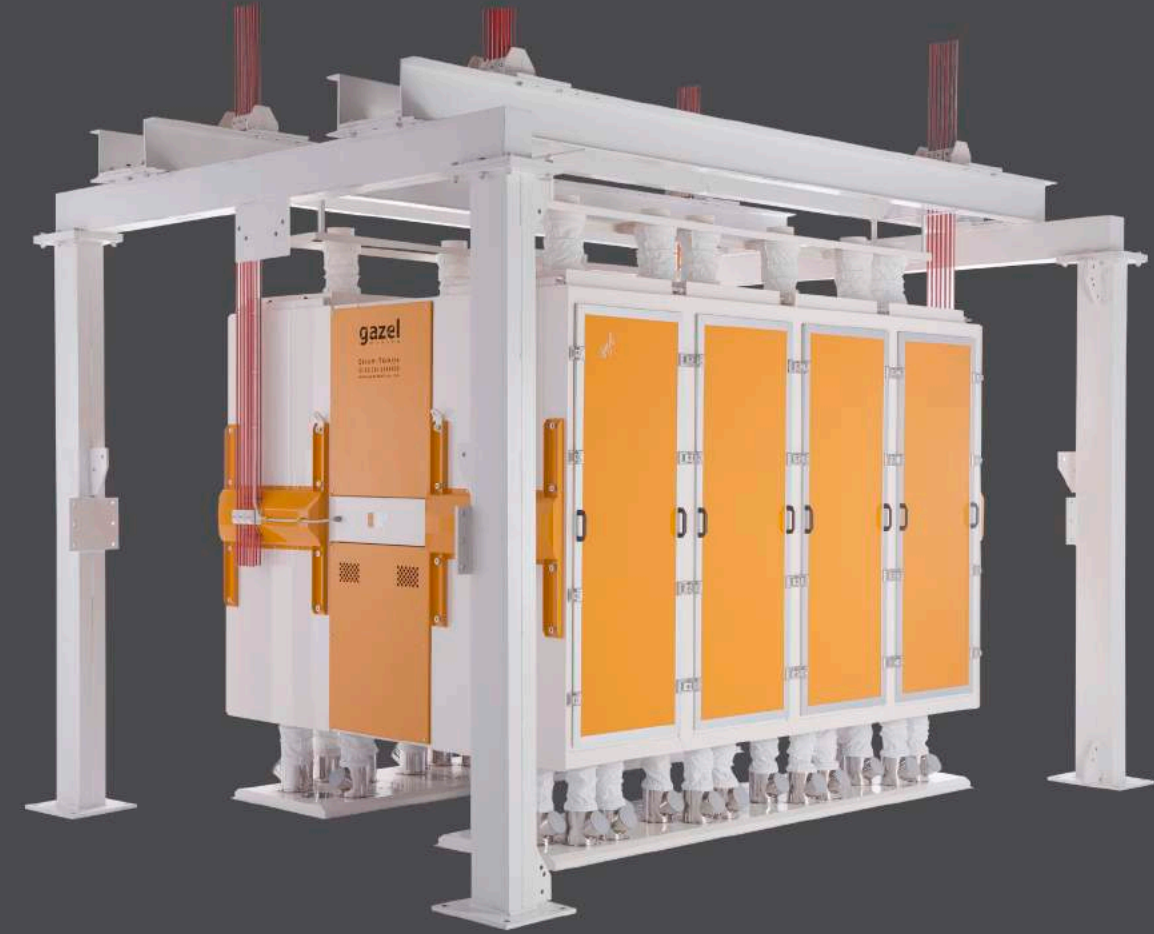

gazel
milling

GMJ 10 (30-28-24-20)

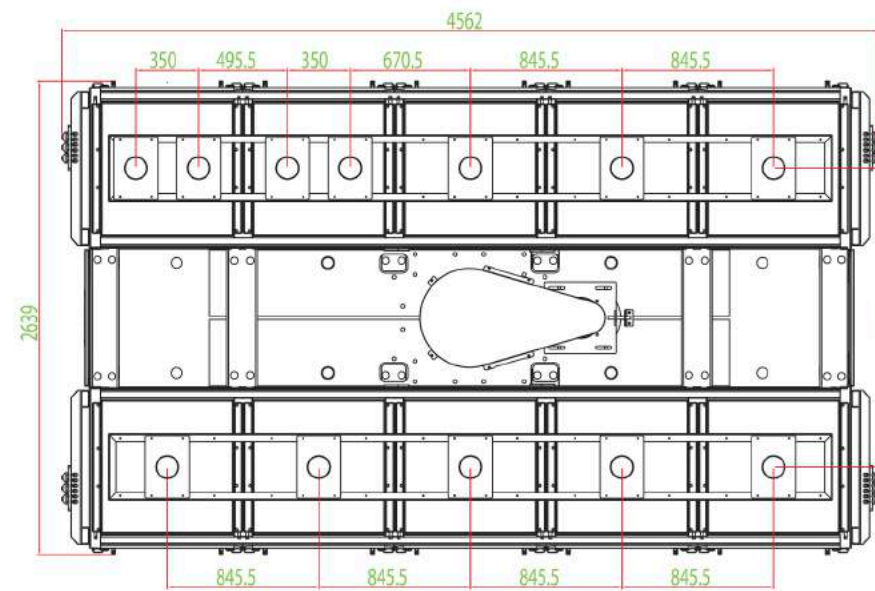
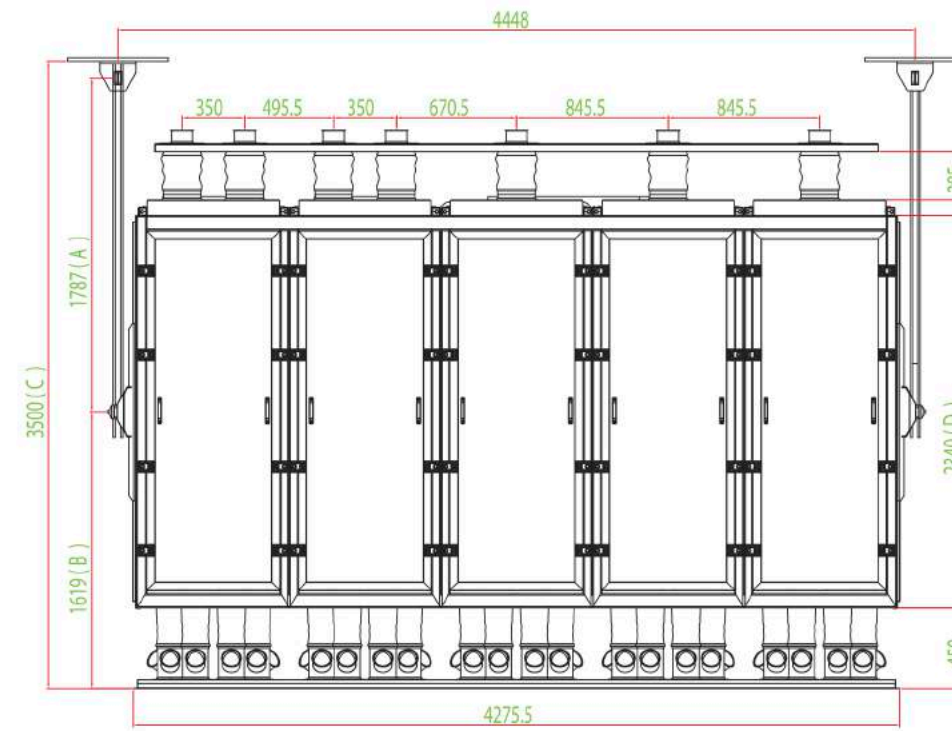

GMJ 8 (30-28-24-20-16)

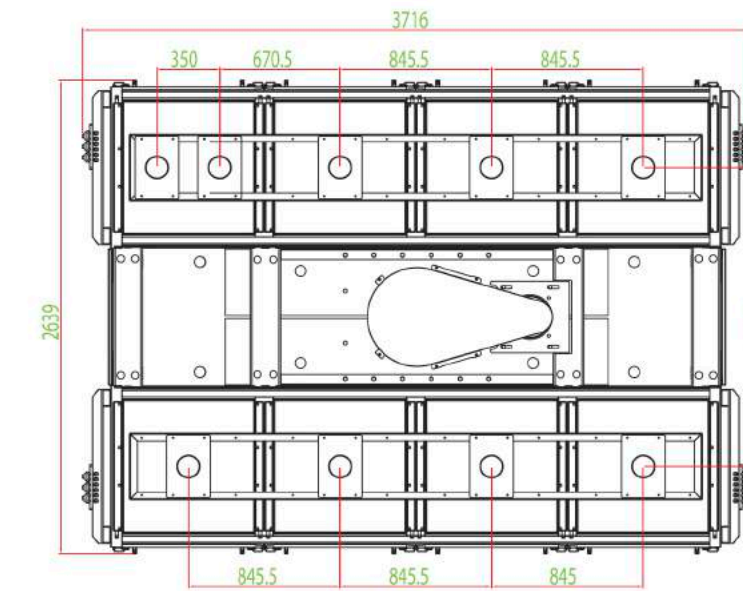
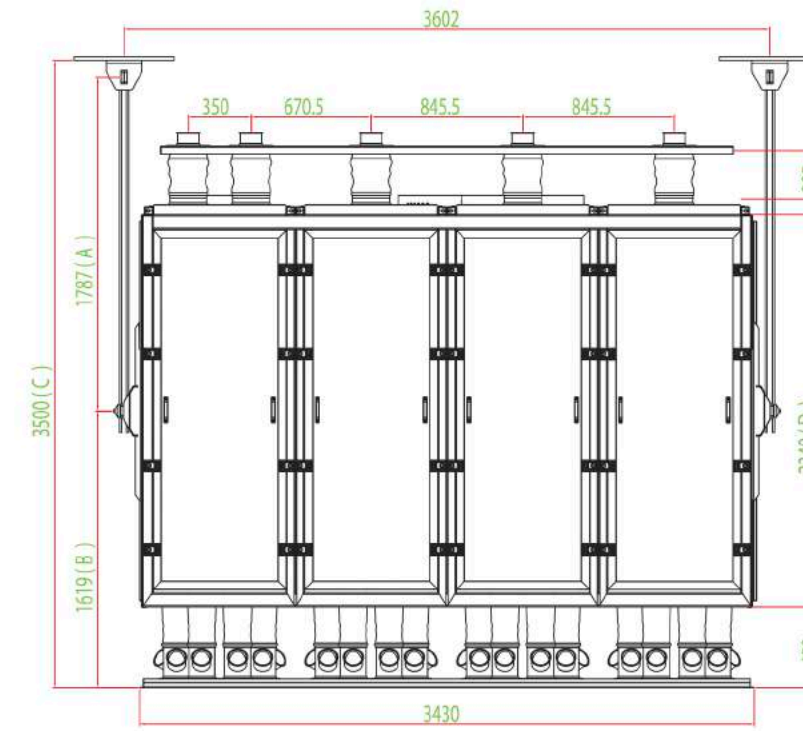

GMJ 6 (30-28-24-20-16)

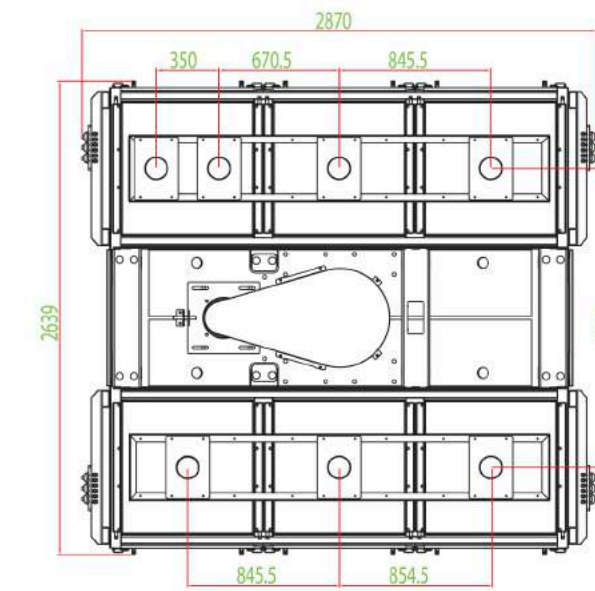
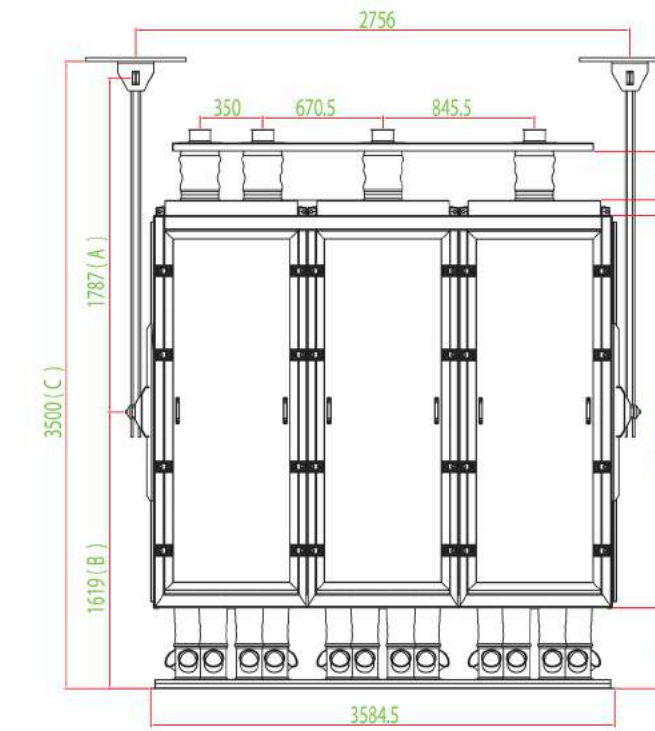

GMJ 4 (30-28-24-20-16)

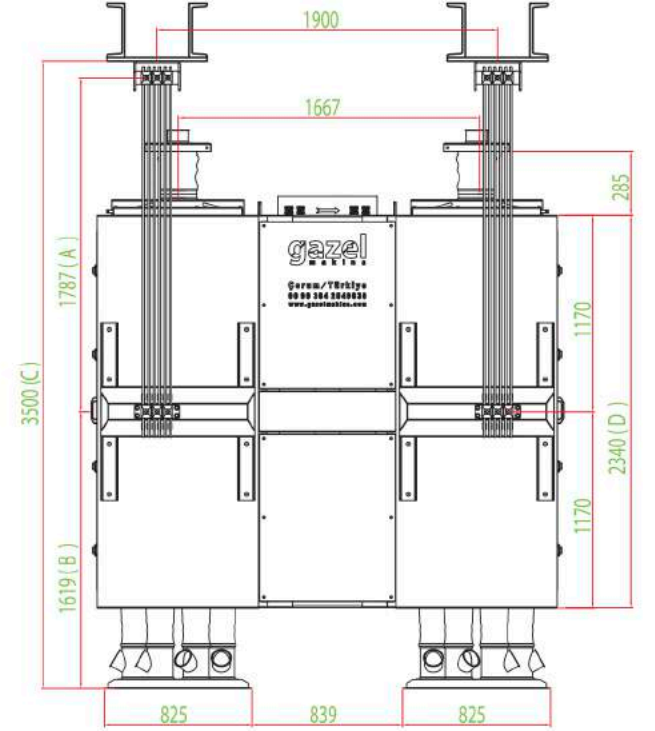
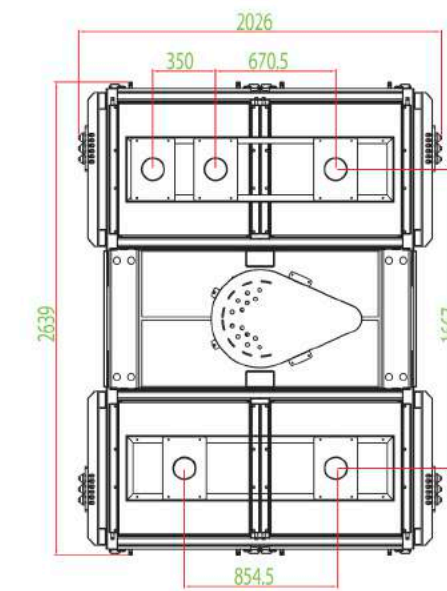
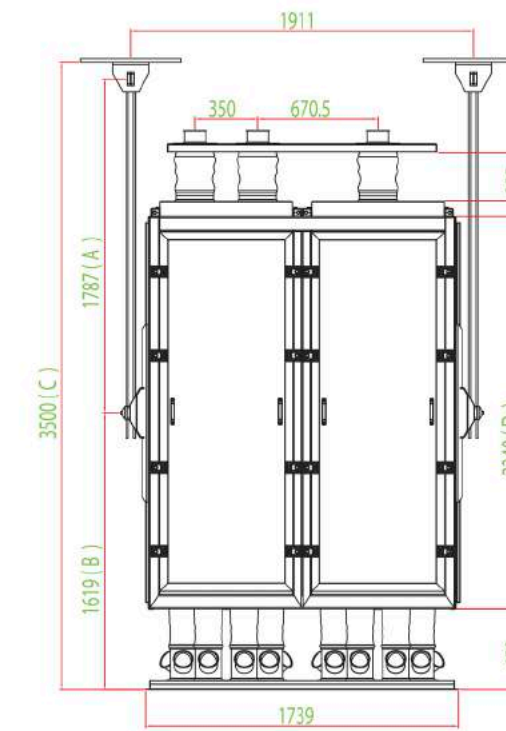

**GMJ SERİSİ
740 x 740**

**GMJ SERIES
740 x 740**

GMJ 10-8

Tip Type	Pasajdaki Eleğin Sayısı Number of Sieves	Ölçüler Measures (mm)				Her Pasajdaki Eleğin Sayısı Number of Sieves per Section	Toplam Kasa Yüksekliği Total Height of Sieves	Yaklaşık Eleme Alanı (m ²) Approximate Sifting Area (m ²)				Motor Devri Engine Speed (rpm)	Makine Devri Machine Speed (rpm)	Motor kw Engine kw	Makine Çalışma Dairesi Çapı Machine Working Circle Diameter (mm)	Yaklaşık Ağırlık Approximate Weight (KG)
		A	B	C (min)	D			G TIP-W TYPE		N TIP-N TYPE						
								Max	Min	Max	Min					
GMJ 10/30	10	1787	1619	3500	2340	30-26	214	144,72	125,42	120,60	104,52	1000	245	11	65	7510
GMJ 10/28	10	1712	1544	3350	2190	28-24	199	135,07	115,78	112,56	96,48	1000	245	11	65	7300
GMJ 10/24	10	1562	1394	3050	1890	24-20	169	115,78	96,48	96,48	80,40	1000	245	11	65	6870
GMJ 10/20	10	1500	1244	2838	1590	20-16	139	96,48	77,18	80,40	64,32	1000	245	7,5	65	6430
GMJ 8/30	8	1787	1619	3500	2340	30-26	214	115,78	100,34	96,48	83,62	1000	245	7,5	65	6500
GMJ 8/28	8	1712	1544	3350	2190	28-24	199	108,06	92,62	90,05	77,18	1000	245	7,5	65	6300
GMJ 8/24	8	1562	1394	3050	1890	24-20	169	92,62	77,18	77,18	64,32	1000	245	7,5	65	5950
GMJ 8/20	8	1500	1244	2838	1590	20-16	139	77,18	61,75	64,32	51,46	1000	245	5,5	65	5500
GMJ 8/16	8	1500	1094	2688	1290	16-12	109	61,75	46,31	51,46	38,59	1000	245	5,5	65	5150

GMJ 6-4

Tip Type	Pasajdaki Eleğin Sayısı Number of Sieves	Ölçüler Measures (mm)				Her Pasajdaki Eleğin Sayısı Number of Sieves per Section	Toplam Kasa Yüksekliği Total Height of Sieves	Yaklaşık Eleme Alanı (m ²) Approximate Sifting Area (m ²)				Motor Devri Engine Speed (rpm)	Makine Devri Machine Speed (rpm)	Motor kw Engine kw	Makine Çalışma Dairesi Çapı Machine Working Circle Diameter (mm)	Yaklaşık Ağırlık Approximate Weight (KG)
		A	B	C (min)	D			G TIP-W TYPE		N TIP-N TYPE						
								Max	Min	Max	Min					
GMJ 6/30	6	1787	1619	3500	2340	30-26	214	86,83	75,25	72,36	62,71	1000	245	5,5	65	5170
GMJ 6/28	6	1712	1544	3350	2190	28-24	199	81,04	69,47	67,54	57,89	1000	245	5,5	65	4970
GMJ 6/24	6	1562	1394	3050	1890	24-20	169	69,47	57,89	57,89	48,24	1000	245	5,5	65	4570
GMJ 6/20	6	1500	1244	2838	1590	20-16	139	57,89	46,31	48,24	38,59	1000	245	5,5	65	4170
GMJ 6/16	6	1500	1094	2688	1290	16-12	109	46,31	34,73	38,59	28,94	1000	245	5,5	65	3740
GMJ 4/30	4	1787	1619	3500	2340	30-26	214	57,89	50,17	48,24	41,81	1000	245	4	65	3800
GMJ 4/28	4	1712	1544	3350	2190	28-24	199	54,03	46,31	45,02	38,59	1000	245	4	65	3600
GMJ 4/24	4	1562	1394	3050	1890	24-20	169	46,31	38,59	38,59	32,16	1000	245	4	65	3200
GMJ 4/20	4	1500	1244	2838	1590	20-16	139	38,59	30,87	32,16	25,73	1000	245	4	65	2800
GMJ 4/16	4	1500	1094	2688	1290	16-12	109	30,87	23,16	25,73	19,30	1000	245	3	65	2350

STANDART
640 x 640 KASALI ELEK

STANDARD SIFTER
WITH 640 x 640 SIEVES

GM
Serisi
GM
Series

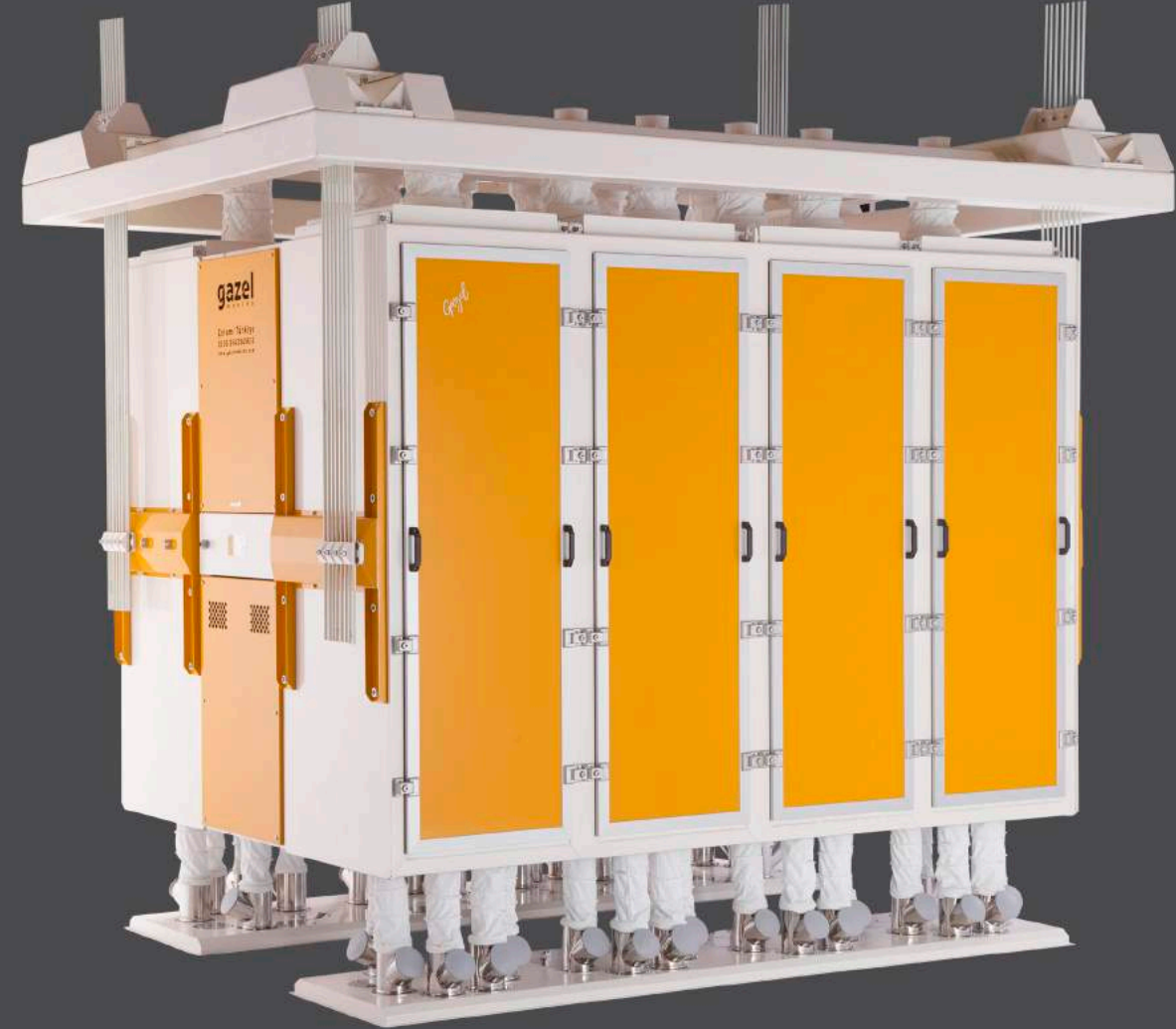

gazel
milling

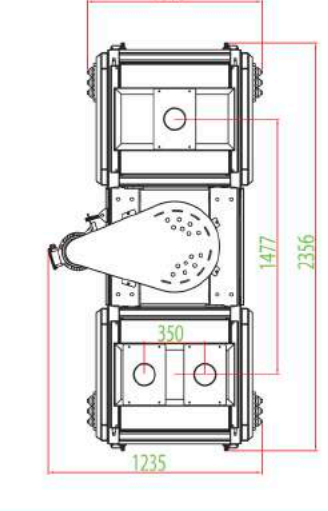
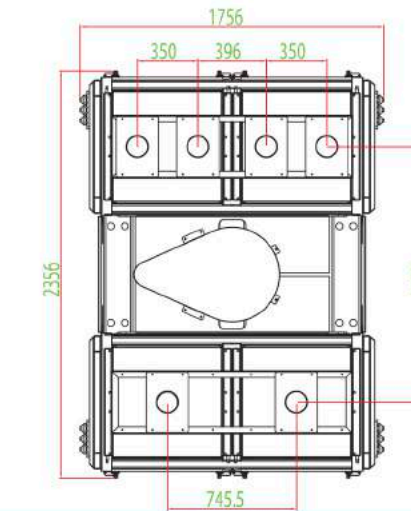
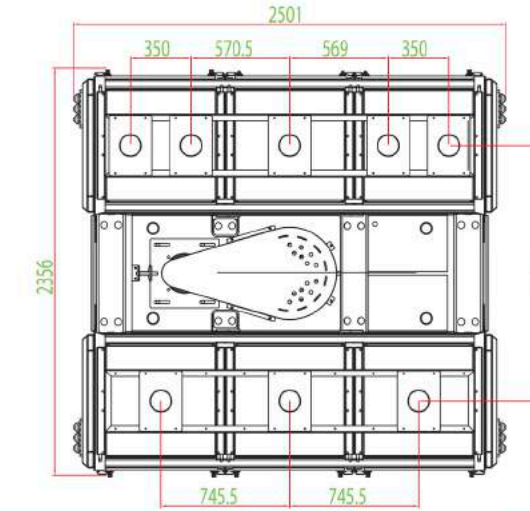
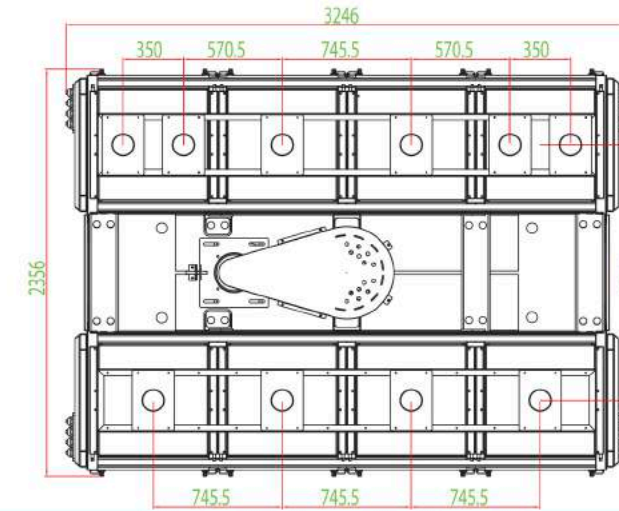
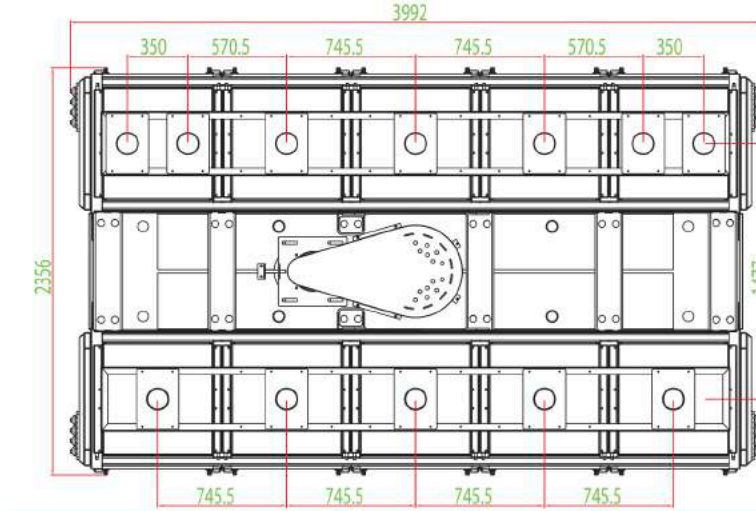
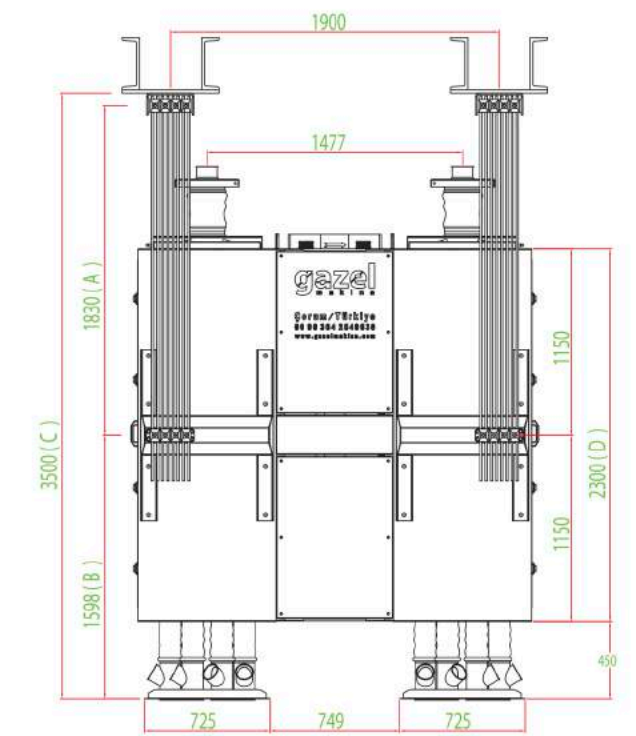
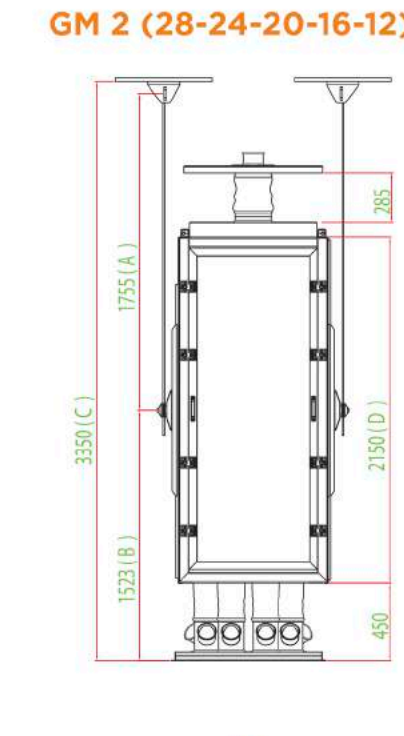
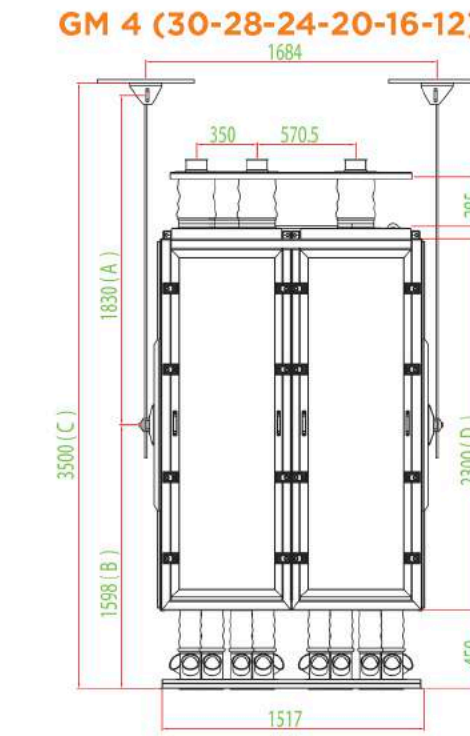
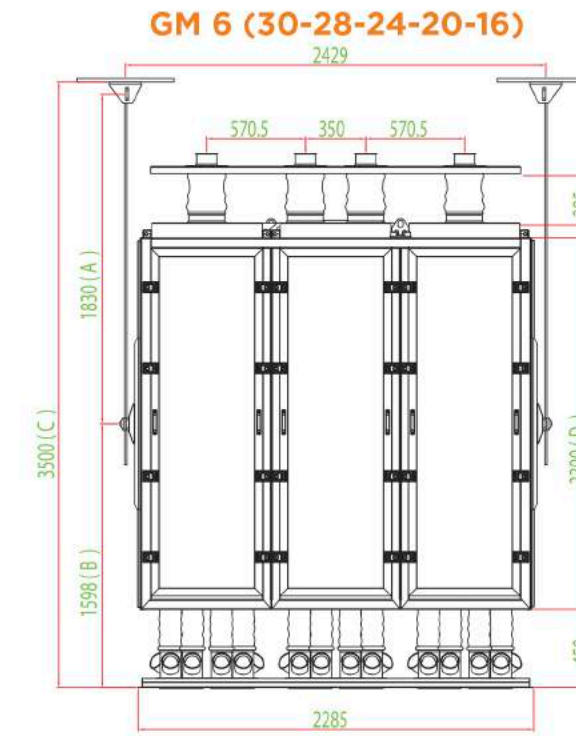
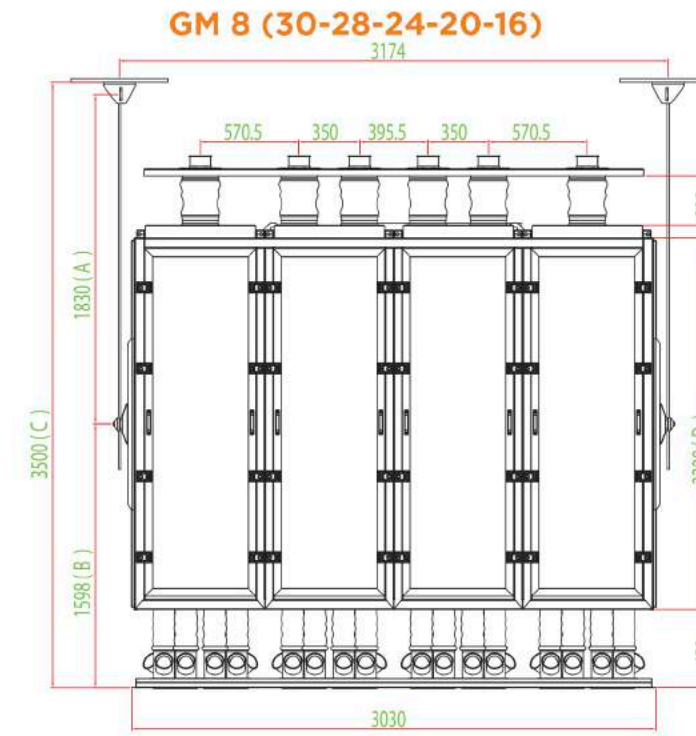
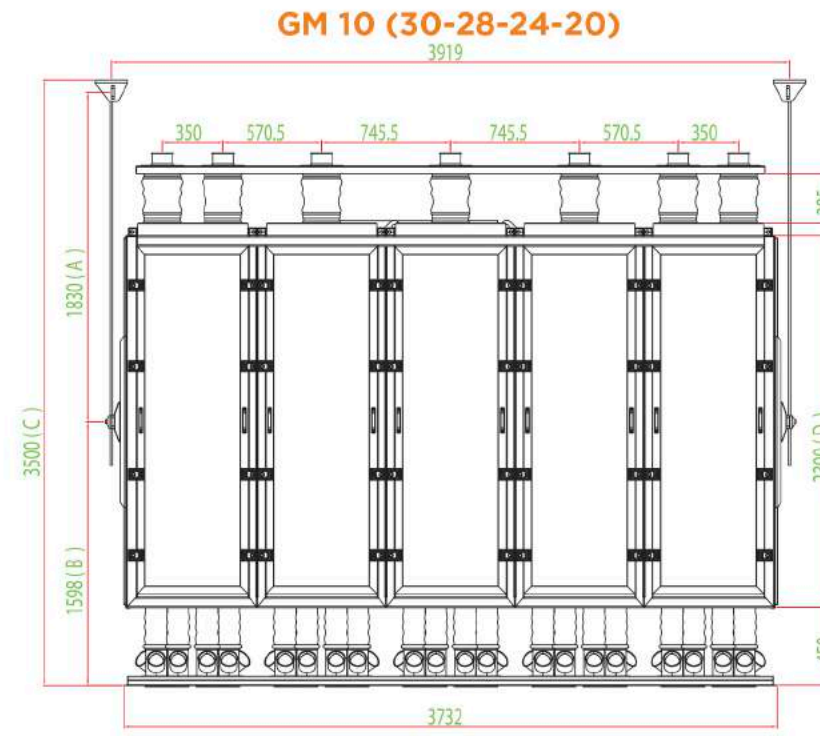

GM SERİSİ
640x640
GM SERIES
640x640

Tip Type	Pasa Sayısı Number of Section	Ölçüler Measures (mm)				Her Pasa'daki Elek Sayısı Number of Sieves per Section	Toplam Kasa Yüksekliği Total Height of Sieves	Yaklaşık Eleme Alanı (m ²) Approximate Sifting Area (m ²)				Motor Devri Engine Speed (rpm)	Makine Devri Machine Speed (rpm)	Motor kw Engine kw	Makine Çalışma Dairesi Çapı Machine Working Circle Diameter (mm)	Yaklaşık Ağırlık Approximate Weight (KG)
		A	B	C (min)	D			G TIP-W TYPE		N TIP-N TYPE						
								Max	Min	Max	Min					
GM 10/30	10	1830	1598	3500	2300	30-26	214	106,02	91,88	85,50	74,10	1000	245	7,5	65	5950
GM 10/28	10	1755	1523	3350	2150	28-24	199	98,95	84,82	79,80	68,40	1000	245	7,5	65	5750
GM 10/24	10	1605	1373	3050	1850	24-20	169	84,82	70,68	68,40	57,00	1000	245	7,5	65	5300
GM 10/20	10	1500	1223	2795	1550	20-16	139	70,68	56,54	57,00	45,60	1000	245	5,5	65	4850
GM 8/30	8	1830	1598	3500	2300	30-26	214	84,82	73,51	68,40	59,28	1000	245	7,5	65	4900
GM 8/28	8	1755	1523	3350	2150	28-24	199	79,16	67,85	63,84	54,72	1000	245	5,5	65	4700
GM 8/24	8	1605	1373	3050	1850	24-20	169	67,85	56,54	54,72	45,60	1000	245	5,5	65	4300
GM 8/20	8	1500	1223	2795	1550	20-16	139	56,54	45,24	45,60	36,48	1000	245	5,5	65	3900
GM 8/16	8	1500	1073	2645	1250	16-12	109	45,24	33,93	36,48	27,36	1000	245	4	65	3400
GM 6/30	6	1830	1598	3500	2300	30-26	214	63,61	55,13	51,30	44,46	1000	245	5,5	65	4050
GM 6/28	6	1755	1523	3350	2150	28-24	199	59,37	50,89	47,88	41,04	1000	245	4	65	3850
GM 6/24	6	1605	1373	3050	1850	24-20	169	50,89	42,41	41,04	34,20	1000	245	4	65	3450
GM 6/20	6	1500	1223	2795	1550	20-16	139	42,41	33,93	34,20	27,36	1000	245	4	65	3050
GM 6/16	6	1500	1073	2645	1250	16-12	109	33,93	25,44	27,36	20,52	1000	245	4	65	2650

Tip Type	Pasa Sayısı Number of Section	Ölçüler Measures (mm)				Her Pasa'daki Elek Sayısı Number of Sieves per Section	Toplam Kasa Yüksekliği Total Height of Sieves	Yaklaşık Eleme Alanı (m ²) Approximate Sifting Area (m ²)				Motor Devri Engine Speed (rpm)	Makine Devri Machine Speed (rpm)	Motor kw Engine kw	Makine Çalışma Dairesi Çapı Machine Working Circle Diameter (mm)	Yaklaşık Ağırlık Approximate Weight (KG)
		A	B	C (min)	D			G TIP-W TYPE		N TIP-N TYPE						
								Max	Min	Max	Min					
GM 4/30	4	1830	1598	3500	2300	30-26	214	42,41	36,75	34,20	29,64	1000	245	4	65	3100
GM 4/28	4	1755	1523	3350	2150	28-24	199	39,58	33,93	31,92	27,36	1000	245	3	65	2950
GM 4/24	4	1605	1373	3050	1850	24-20	169	33,93	28,27	27,36	22,80	1000	245	3	65	2650
GM 4/20	4	1500	1223	2795	1550	20-16	139	28,27	22,62	22,80	18,24	1000	245	3	65	2360
GM 4/16	4	1500	1073	2645	1250	16-12	109	22,62	16,96	18,24	13,68	1000	245	3	65	2070
GM 4/12	4	1500	923	2495	950	12-8	79	16,96	11,31	13,68	9,12	1000	245	3	65	1750
GM 2/28	2	1755	1523	3350	2150	28-24	199	19,79	16,96	15,96	13,68	1000	245	2,2	65	2250
GM 2/24	2	1605	1373	3050	1850	24-20	169	16,96	14,14	13,68	11,40	1000	245	2,2	65	1950
GM 2/20	2	1500	1223	2795	1550	20-16	139	14,14	11,31	11,40	9,12	1000	245	2,2	65	1650
GM 2/16	2	1500	1073	2645	1250	16-12	109	11,31	8,48	9,12	6,84	1000	245	2,2	65	1350
GM 2/12	2	1500	923	2495	950	12-8	79	8,48	5,65	6,84	4,56	1000	245	2,2	65	1090

EKSTRA PASAJLI
640 x 640 KASALI ELEK

EXTRA SECTION
WITH 640 x 640 SIEVES

GM+
Serisi

GM+
Series

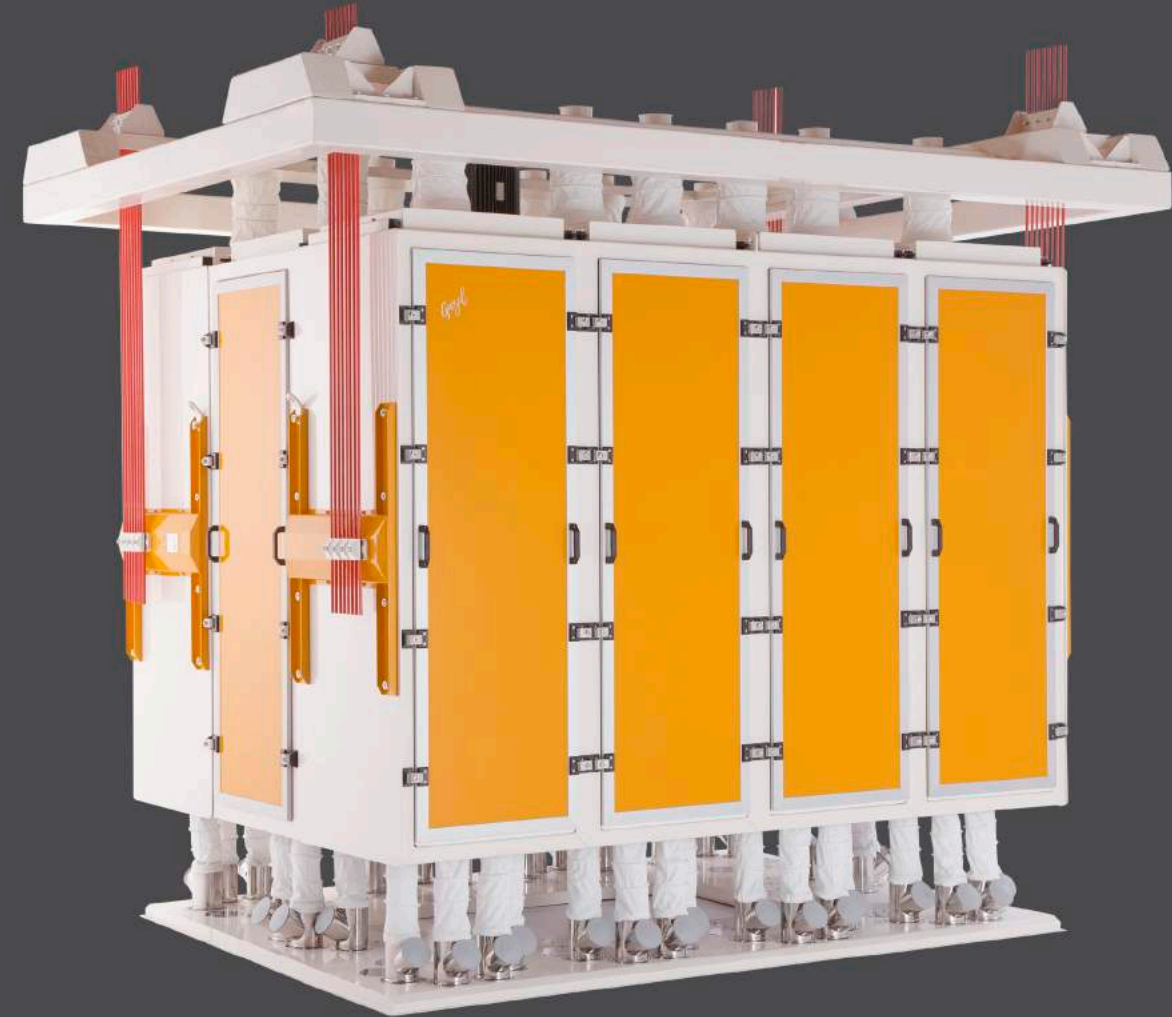

gazel
milling

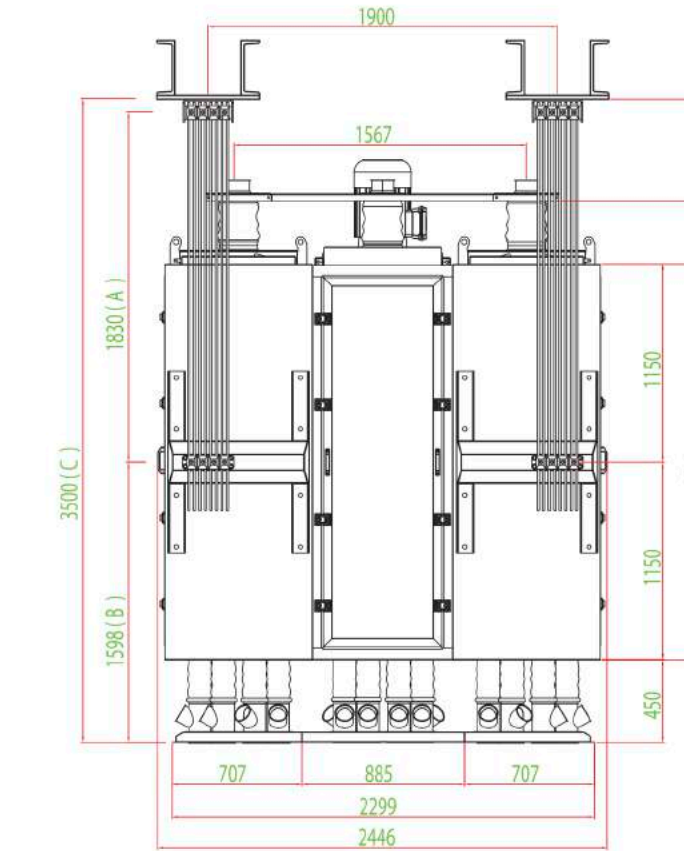
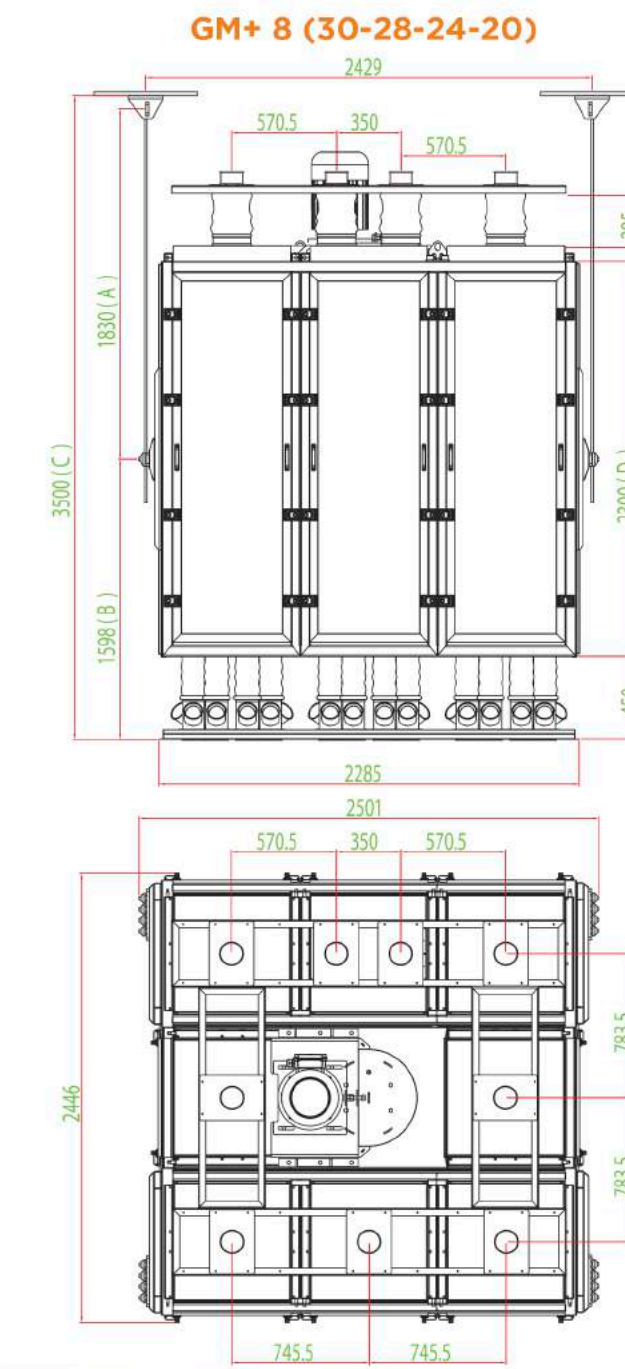
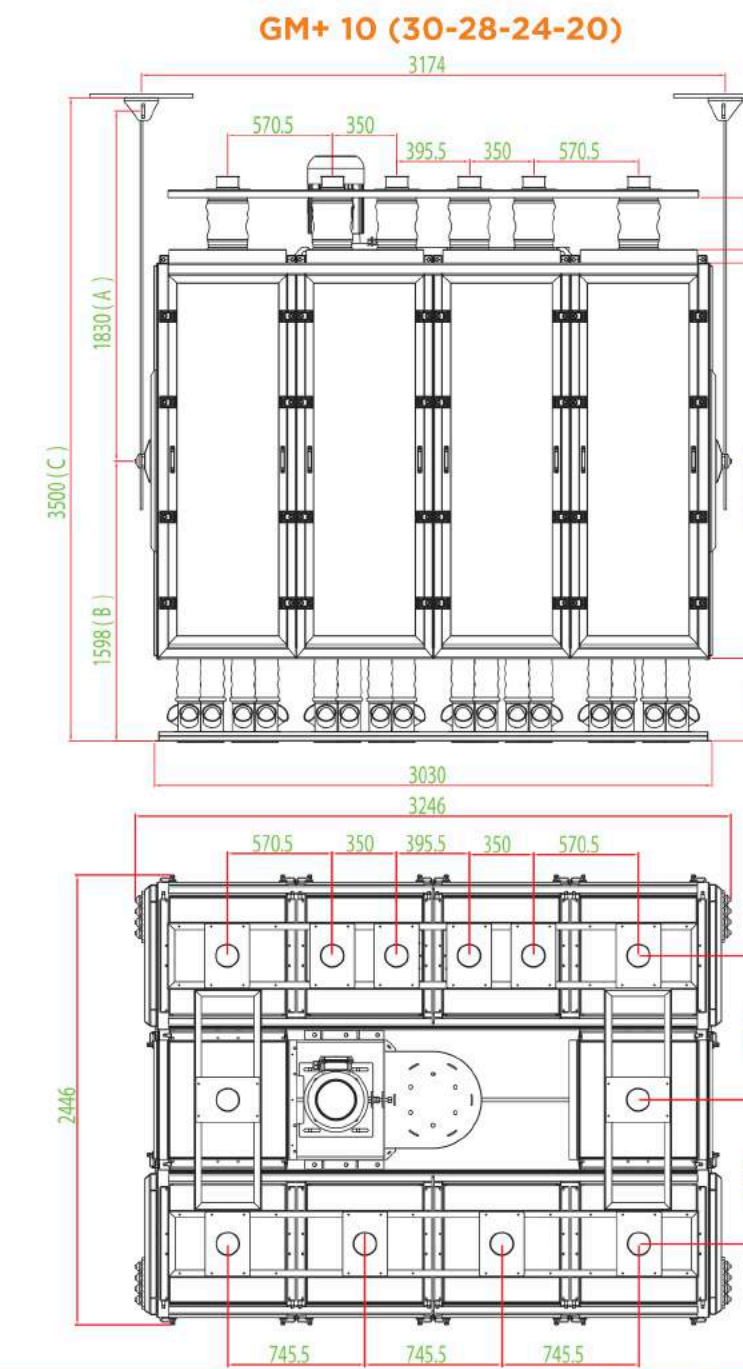
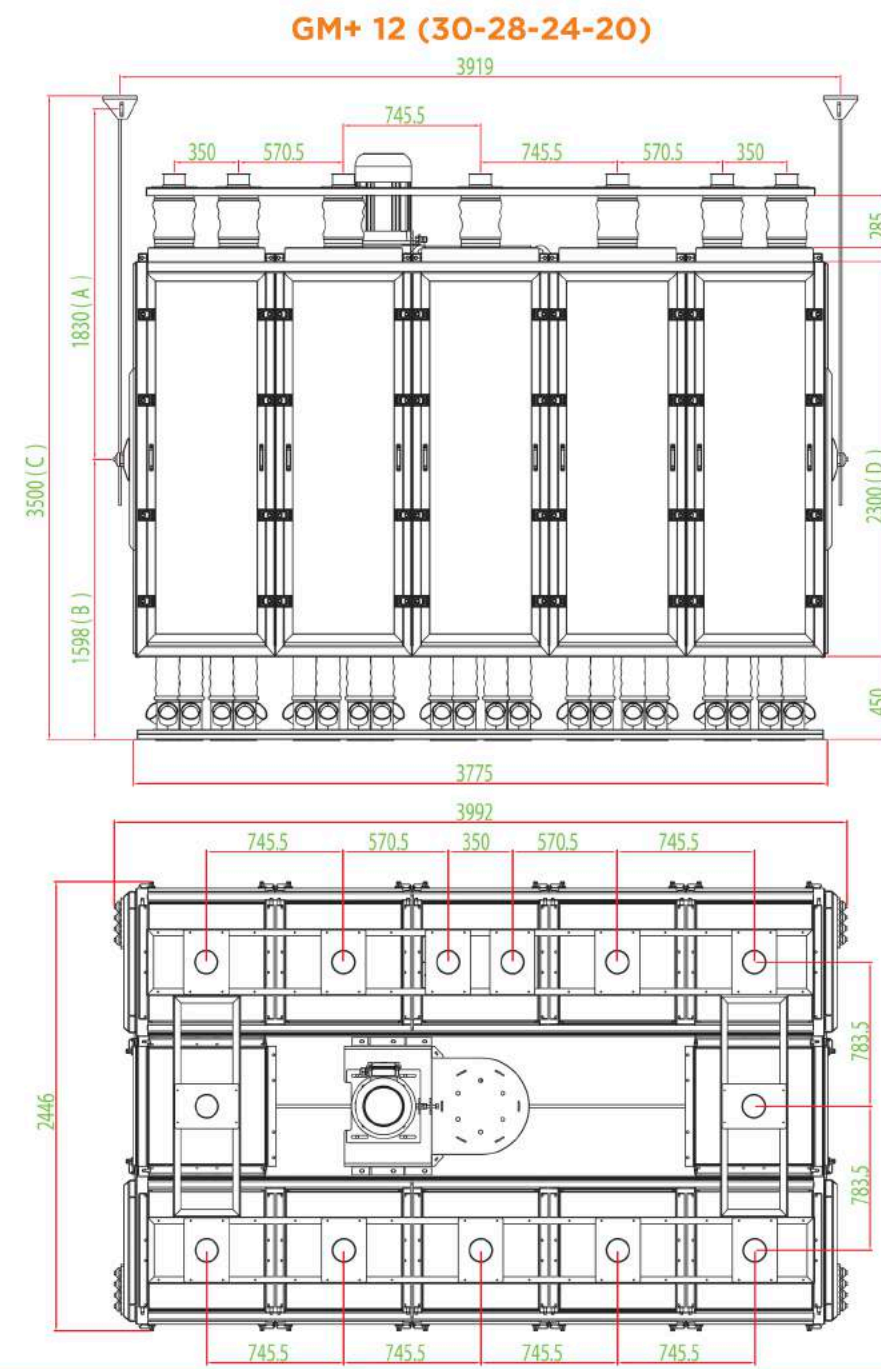

GM+ 12-10-8

Tip Type	Pasaj Sayısı Number of Section	Ölçüler Measures (mm)				Her Pasajdaki Elek Sayısı Number of Sieves per Section	Toplam Kasa Yüksekliği Total Height of Sieves	Yaklaşık Eleme Alanı (m ²) Approximate Sifting Area (m ²)				Motor Devri Engine Speed (rpm)	Makine Devri Machine Speed (rpm)	Motor kw Engine kw	Makine Çalışma Dairesi Çapı Machine Working Circle Diameter (mm)	Yaklaşık Ağırlık Approximate Weight (KG)
		A	B	C (min)	D			G TIP-N TYPE		N TIP-N TYPE						
								Max	Min	Max	Min					
GM+ 12 / 30	12	1830	1598	3500	2300	30-26	214	127,22	110,26	102,60	88,92	1000	245	11	65	7050
GM+ 12 / 28	12	1755	1523	3350	2150	28-24	199	118,74	101,78	95,76	82,08	1000	245	11	65	6850
GM+ 12 / 24	12	1605	1373	3050	1850	24-20	169	101,78	84,82	82,08	68,40	1000	245	11	65	6400
GM+ 12 / 20	12	1500	1223	2795	1550	20-16	139	84,82	67,85	68,40	54,72	1000	245	7,5	65	5990
GM+ 10 / 30	10	1830	1598	3500	2300	30-26	214	106,02	91,88	85,50	74,10	1000	245	7,5	65	5800
GM+ 10 / 28	10	1755	1523	3350	2150	28-24	199	98,95	84,82	79,80	68,40	1000	245	7,5	65	5620
GM+ 10 / 24	10	1605	1373	3050	1850	24-20	169	84,82	70,68	68,40	57,00	1000	245	7,5	65	5200
GM+ 10 / 20	10	1500	1223	2795	1550	20-16	139	70,68	56,54	57,00	45,60	1000	245	7,5	65	4800
GM+ 8 / 30	8	1830	1598	3500	2300	30-26	214	84,82	73,51	68,40	59,28	1000	245	5,5	65	4850
GM+ 8 / 28	8	1755	1523	3350	2150	28-24	199	79,16	67,85	63,84	54,72	1000	245	5,5	65	4650
GM+ 8 / 24	8	1605	1373	3050	1850	24-20	169	67,85	56,54	54,72	45,60	1000	245	5,5	65	4250
GM+ 8 / 20	8	1500	1223	2795	1550	20-16	139	56,54	45,24	45,60	36,48	1000	245	5,5	65	3850



**GM+ SERİSİ
EKSTRA
PASAJLI
640 x 640**

**GM+ SERIES
EXTRA
SECTION
640 x 640**

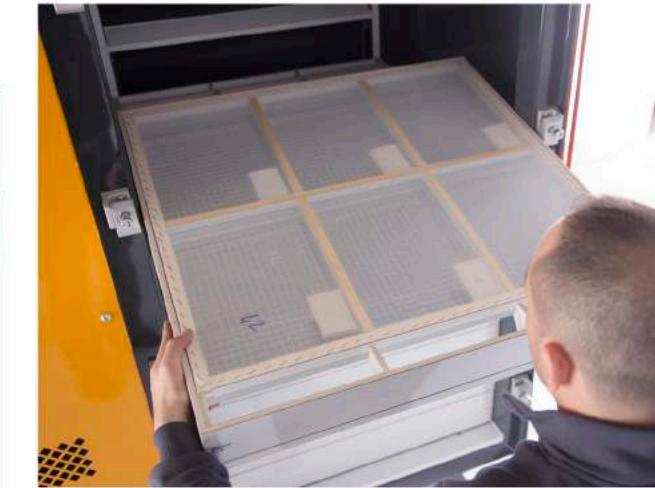

**PROFİL ŞASELİ
640 x 640 KASALI ELEK**

INCLUDING CHASSIS
WITH 640 x 640 SIEVES

GMC
Serisi
GMC
Series



gazel
milling

GMC 10 (30-28-24-20)

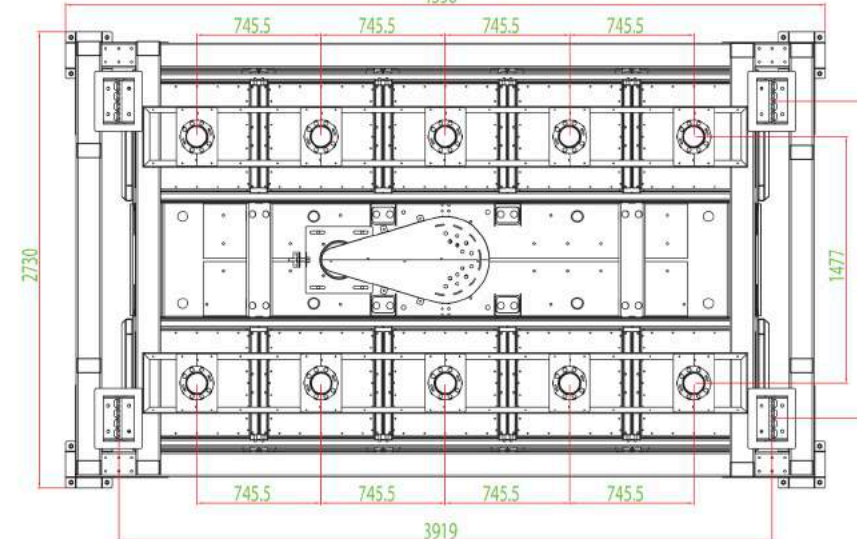
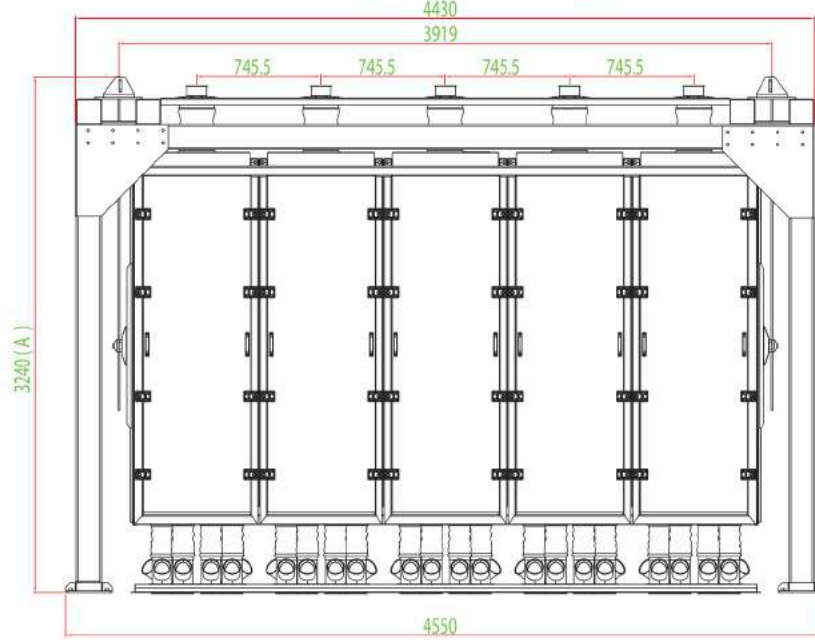

GMC 8 (30-28-24-20-16)

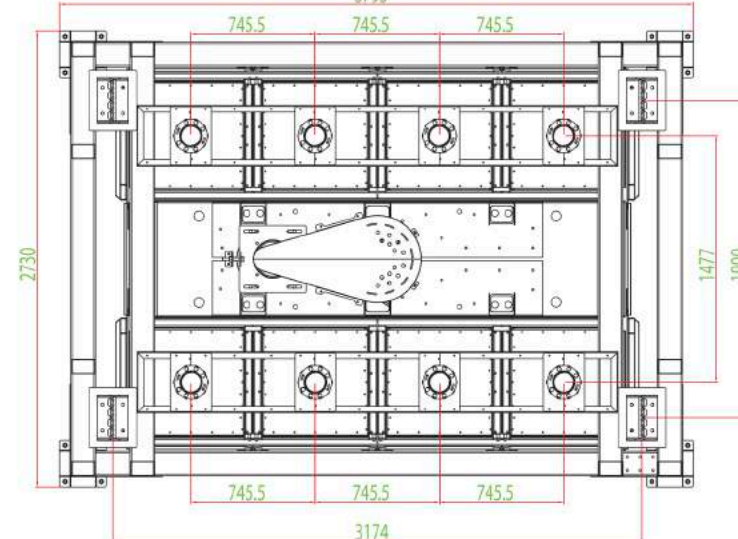
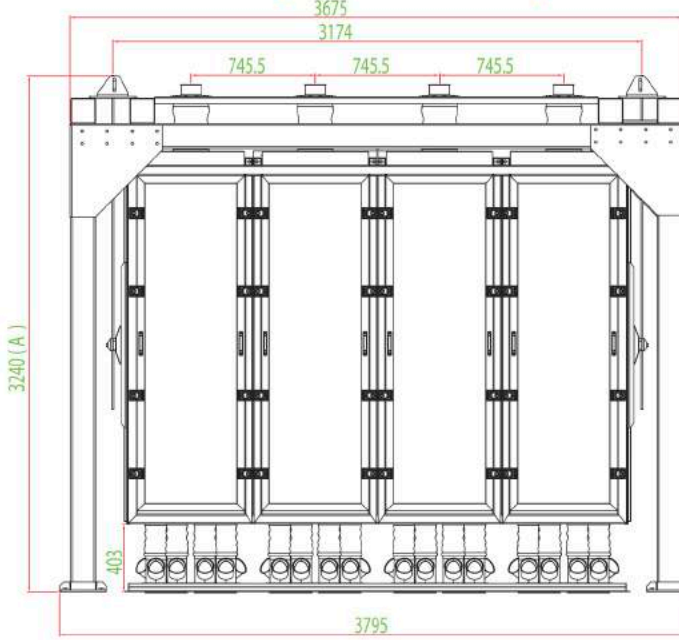

GMC 6 (30-28-24-20-16)

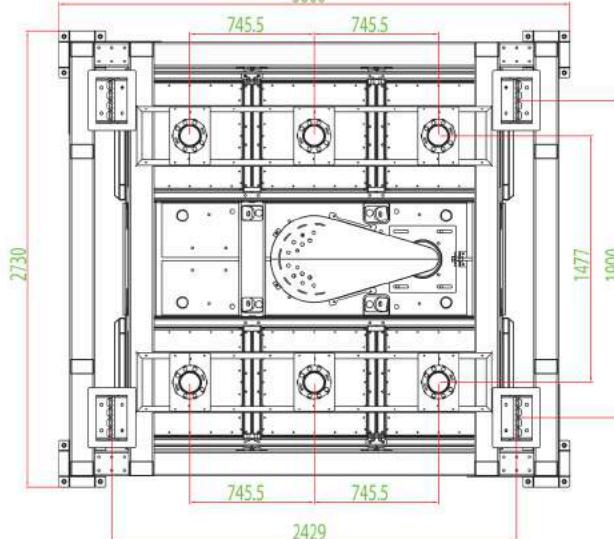
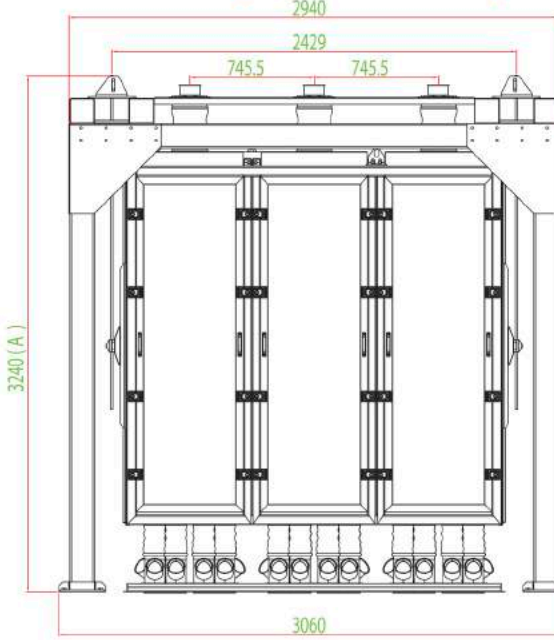

GMC 4 (30-28-24-20-16-12)

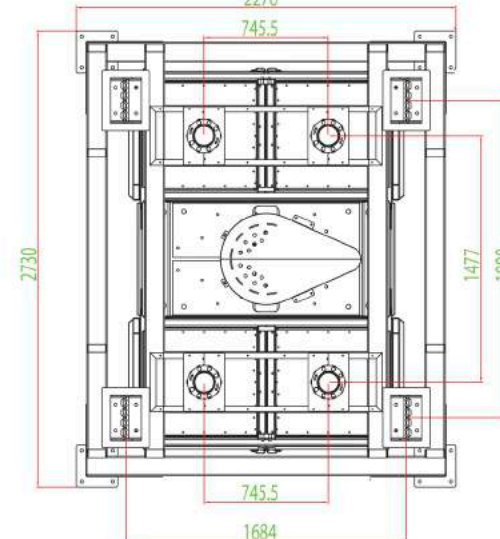
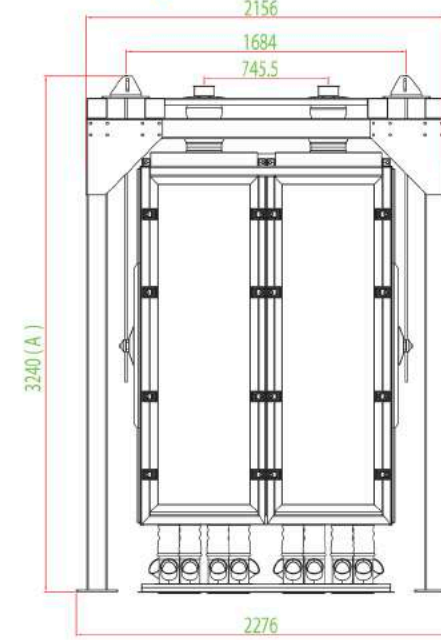

GMC 2 (28-24-20-16-12)

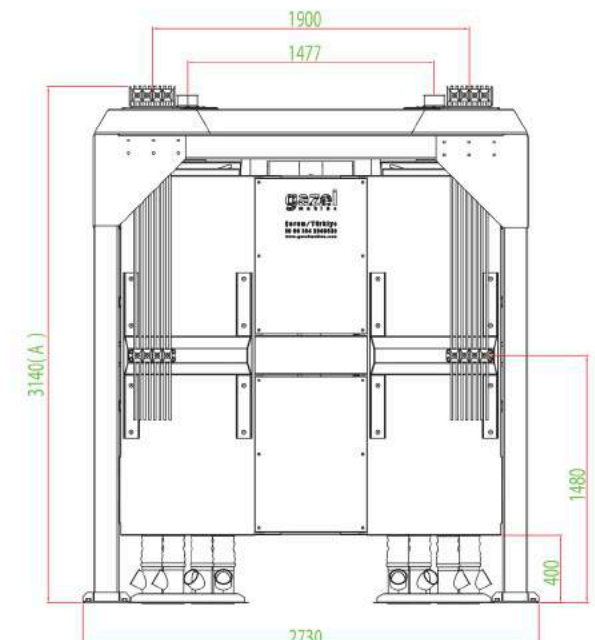
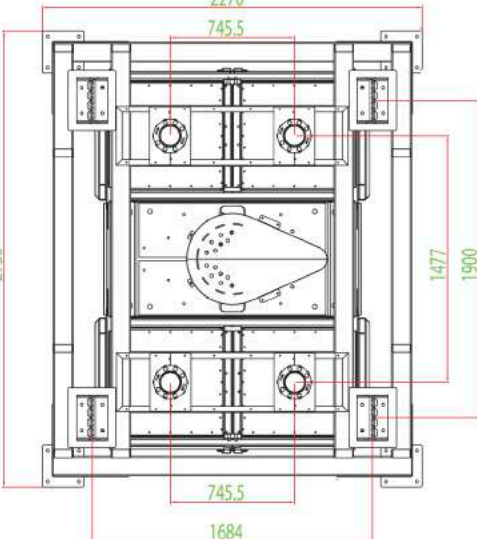
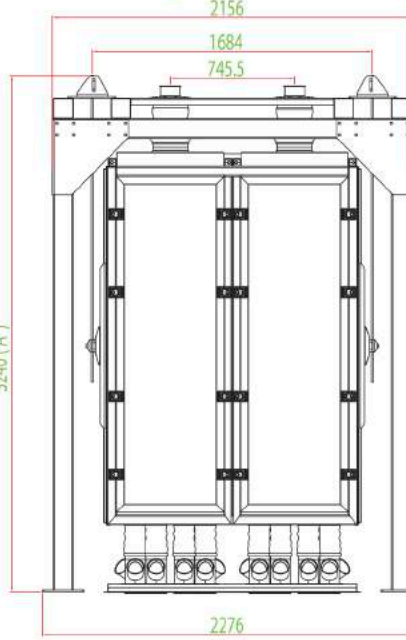

GMC 10-8-6

Tip Type	Pasaj Sayısı Number of Section	Ölçüler Measures (mm) A	Her Pasajdaki Elek Sayısı Number of Sieves per Section	Toplam Kasa Yüksekliği Total Height of Sieves	Yaklaşık Eleme Alanı (m ²) Approximate Sifting Area (m ²)				Motor Devri Engine Speed (rpm)	Makine Devri Machine Speed (rpm)	Motor kw Engine kw	Makine Çalışma Dairesi Çapı Machine Working Circle Diameter (mm)	Yaklaşık Ağırlık Approximate Weight (KG)
					G TIP-W TYPE		N TIP-N TYPE						
					Max	Min	Max	Min					
GMC 10/30	10	3240	30-26	214	106,02	91,88	85,50	74,10	1000	245	7,5	65	6880
GMC 10/28	10	3090	28-24	199	98,95	84,82	79,80	68,40	1000	245	7,5	65	6610
GMC 10/24	10	2790	24-20	169	84,82	70,68	68,40	57,00	1000	245	7,5	65	6140
GMC 10/20	10	2490	20-16	139	70,68	56,54	57,00	45,60	1000	245	5,5	65	5670
GMC 8/30	8	3240	30-26	214	84,82	73,51	68,40	59,28	1000	245	7,5	65	5800
GMC 8/28	8	3090	28-24	199	79,16	67,85	63,84	54,72	1000	245	5,5	65	5510
GMC 8/24	8	2790	24-20	169	67,85	56,54	54,72	45,60	1000	245	5,5	65	4990
GMC 8/20	8	2490	20-16	139	56,54	45,24	45,60	36,48	1000	245	5,5	65	4350
GMC 8/16	8	2190	16-12	109	45,24	33,93	36,48	27,36	1000	245	4	65	3890
GMC 6/30	6	3240	30-26	214	63,61	55,13	51,30	44,46	1000	245	5,5	65	4770
GMC 6/28	6	3090	28-24	199	59,37	50,89	47,88	41,04	1000	245	4	65	4560
GMC 6/24	6	2790	24-20	169	50,89	42,41	41,04	34,20	1000	245	4	65	4140
GMC 6/20	6	2490	20-16	139	42,41	33,93	34,20	27,36	1000	245	4	65	3720
GMC 6/16	6	2190	16-12	109	33,93	25,44	27,36	20,52	1000	245	4	65	3300

GMC 4-2

Tip Type	Pasaj Sayısı Number of Section	Ölçüler Measures (mm) A	Her Pasajdaki Elek Sayısı Number of Sieves per Section	Toplam Kasa Yüksekliği Total Height of Sieves	Yaklaşık Eleme Alanı (m ²) Approximate Sifting Area (m ²)				Motor Devri Engine Speed (rpm)	Makine Devri Machine Speed (rpm)	Motor kw Engine kw	Makine Çalışma Dairesi Çapı Machine Working Circle Diameter (mm)	Yaklaşık Ağırlık Approximate Weight (KG)
					G TIP-W TYPE		N TIP-N TYPE						
					Max	Min	Max	Min					
GMC 4/30	4	3240	30-26	214	42,41	36,75	34,20	29,64	1000	245	4	65	3550
GMC 4/28	4	3090	28-24	199	39,58	33,93	31,92	27,36	1000	245	3	65	3400
GMC 4/24	4	2790	24-20	169	33,93	28,27	27,36	22,80	1000	245	3	65	3100
GMC 4/20	4	2490	20-16	139	28,27	22,62	22,80	18,24	1000	245	3	65	2800
GMC 4/16	4	2190	16-12	109	22,62	16,96	18,24	13,68	1000	245	3	65	2500
GMC 4/12	4	1890	12-8	79	16,96	11,31	13,68	9,12	1000	245	3	65	2200
GMC 2/28	2	3090	28-24	199	19,79	16,96	15,96	13,68	1000	245	2,2	65	2600
GMC 2/24	2	2790	24-20	169	16,96	14,14	13,68	11,40	1000	245	2,2	65	2300
GMC 2/20	2	2490	20-16	139	14,14	11,31	11,40	9,12	1000	245	2,2	65	1975
GMC 2/16	2	2190	16-12	109	11,31	8,48	9,12	6,84	1000	245	2,2	65	1650
GMC 2/12	2	1890	12-8	79	8,48	5,65	6,84	4,56	1000	245	2,2	65	1450

**GMC SERİSİ
PROFİL ŞASELİ
640 x 640**

**GMC SERIES
WITH CHASSIS
640 x 640**

GMA 1000 SERİSİ

GMA 1000 SERIES

GMA 740 SERİSİ

GMA 740 SERIES

GMAD 740 SERİSİ

GMAD 740 SERIES

GMA 1000 (12-8)

GMA 740 (12-8)

GMAD 740 (12-8)

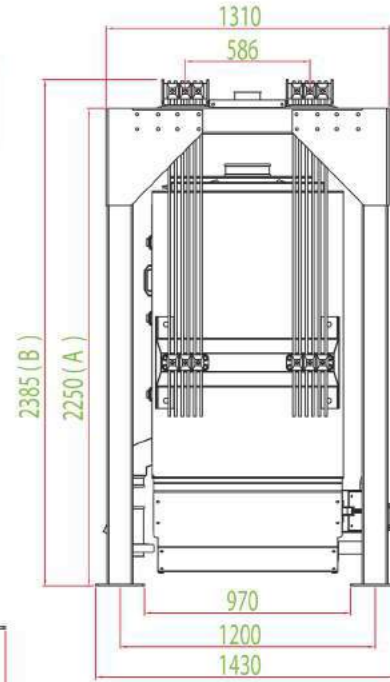
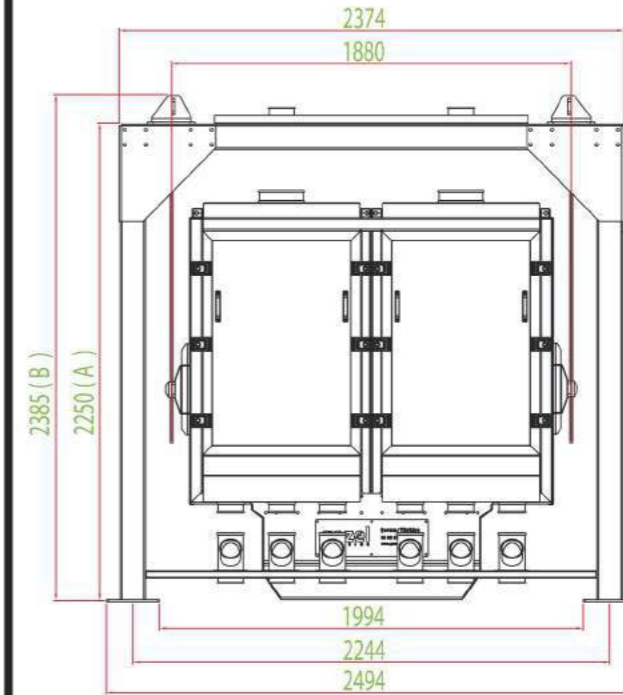
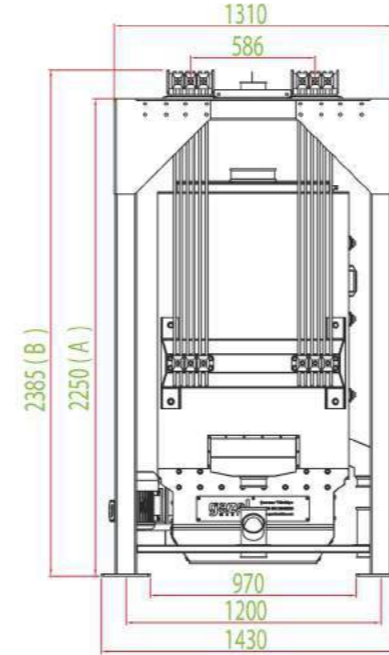
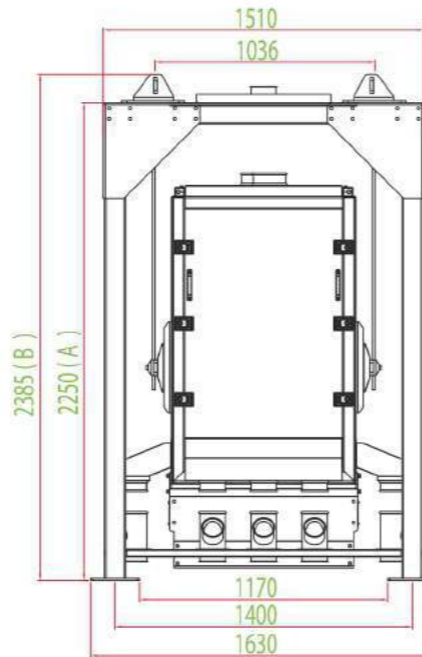
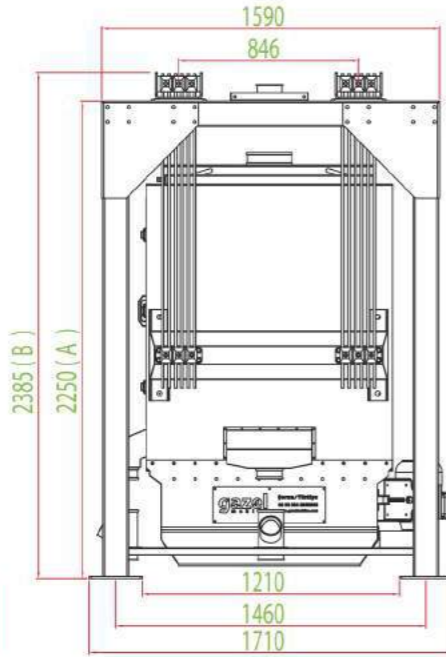
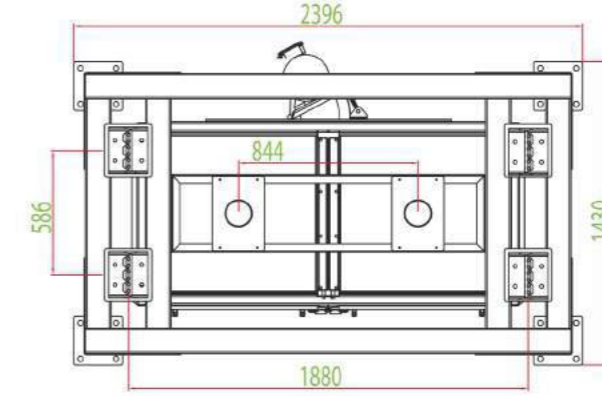
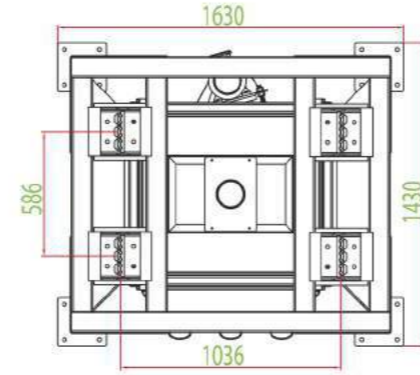
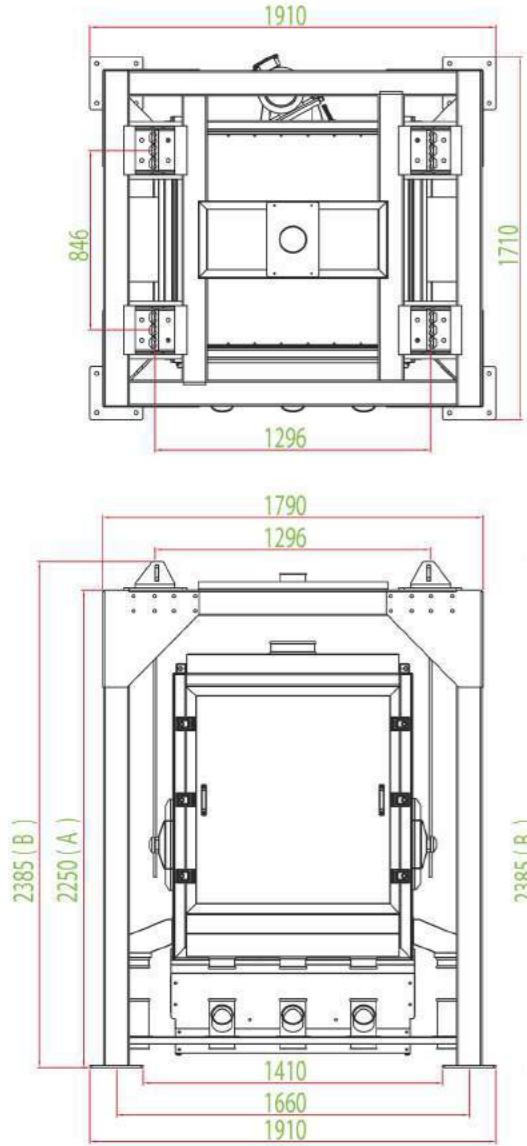

Tip Type	Pasaaj Sayısı Number of Section	Ölçüler Measures (mm)		Her Pasaajdaki Elek Sayısı Number of Sieves per Section	Toplam Kasa Yüksekliği Total Height of Sieves	Yaklaşık Eleme Alanı (m ²) Approximate Sifting Area (m ²)				Motor Devri Engine Speed (rpm)	Makine Devri Machine Speed (rpm)	Motor kw Engine kw	Makine Çalışma Dairesi Çapı Machine Working Circle Diameter (mm)	Yaklaşık Ağırlık Approximate Weight (KG)
		A	B			G TIP-W TYPE		N TIP-N TYPE						
						Max	Min	Max	Min					
GMA 1/8-740	1	2100	2085	8-4	89	2,83	1,41	2,28	1,14	1000	245	1,1	65	1010
GMA 1/12-740	1	2250	2385	12-8	119	4,24	2,83	3,42	2,28	1000	245	1,5	65	1080
GMA 1/8-1000	1	2100	2085	8-4	89	6,98	3,49	-	-	1000	245	1,5	65	1100
GMA 1/12-1000	1	2250	2385	12-8	119	10,47	6,98	-	-	1000	245	1,5	65	1400
GMA 2/8-740	2	2100	2085	8-4	89	5,65	2,83	4,56	2,28	1000	245	1,5	65	1450
GMA 2/12-740	2	2250	2385	12-8	119	8,48	5,65	6,84	4,56	1000	245	2,2	65	1750



**YÜKSEK KAPASİTELİ KONTROL ELEĞİ
740 x 740 KASALI**

HIGH CAPACITY CONTROL SIFTER
WITH 740 x 740 SIEVES

GMS
Serisi

GMS
Series



GMS
SERİSİ

GMS
SERIES

GMS (24-20-16)

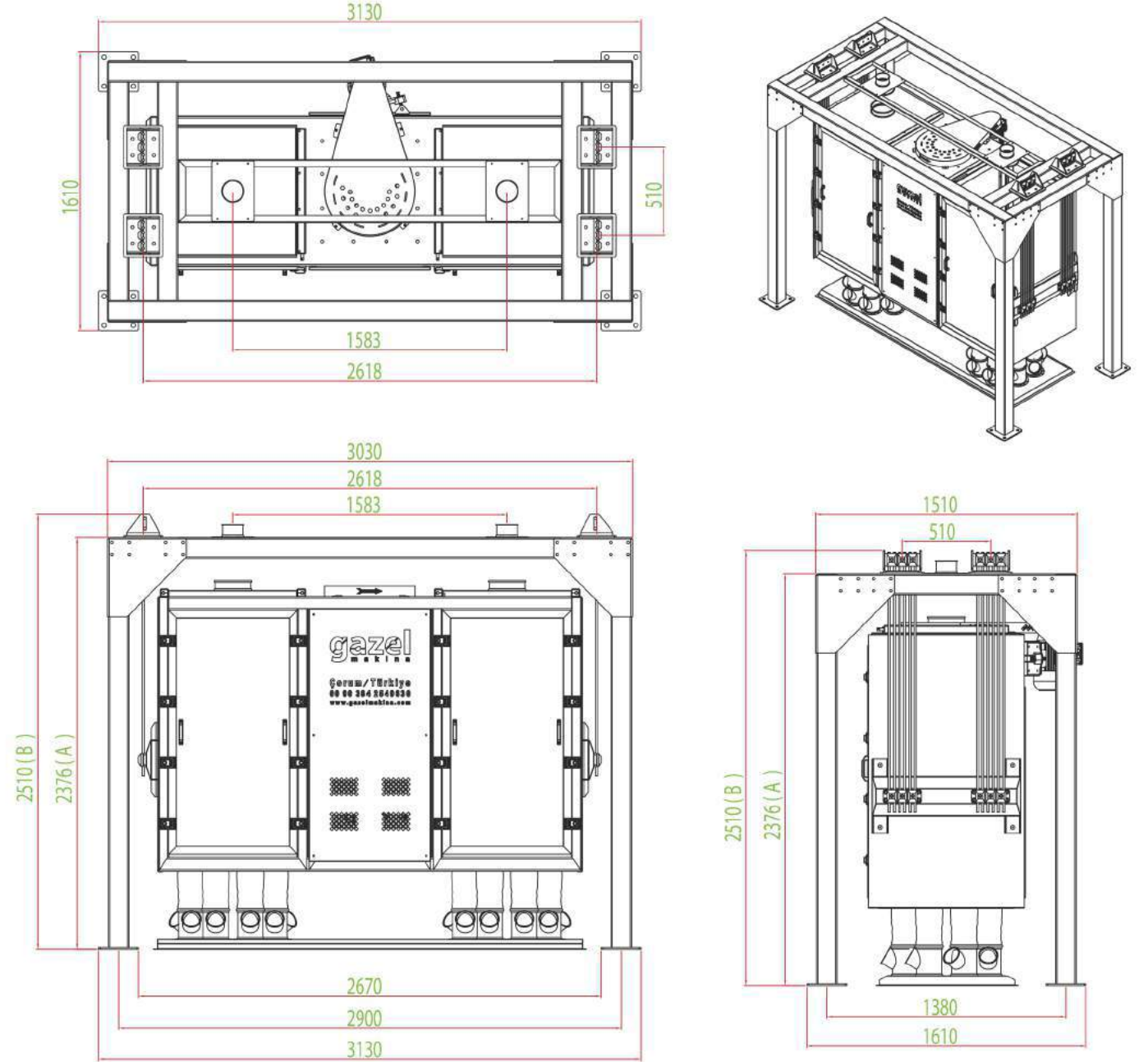

gazel
milling

Tip Type	P pasaj Sayısı Number of Section	Ölçüler Measures (mm)		Her Pasajdaki Elek Sayısı Number of Sieves per Section	Toplam Kasa Yüksekliği Total Height of Sieves	Yaklaşık Eleme Alanı (m ²) Approximate Sifting Area (m ²)				Motor Devri Engine Speed (rpm)	Makine Devri Machine Speed (rpm)	Motor kw Engine kw	Makine Çalışma Dairesi Çapı Machine Working Circle Diameter (mm)	Yaklaşık Ağırlık Approximate Weight (KG)
		A	B			G TIP-W TYPE		N TIP-N TYPE						
						Max	Min	Max	Min					
GMS 2/24	2	2676	2810	24-20	169	23,16	19,30	19,30	16,08	1000	245	3	65	3200
GMS 2/20	2	2376	2510	20-16	139	19,30	15,44	16,08	12,86	1000	245	2,2	65	2800
GMS 2/16	2	2076	2210	16-12	109	15,44	11,58	12,86	9,65	1000	245	2,2	65	2350

GMS (24-20-16)

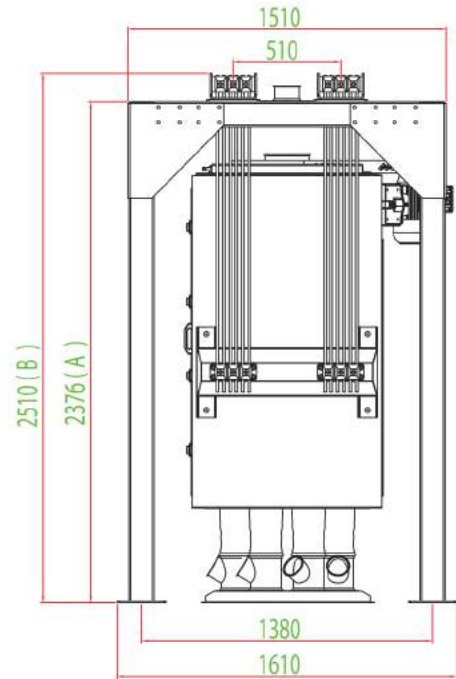
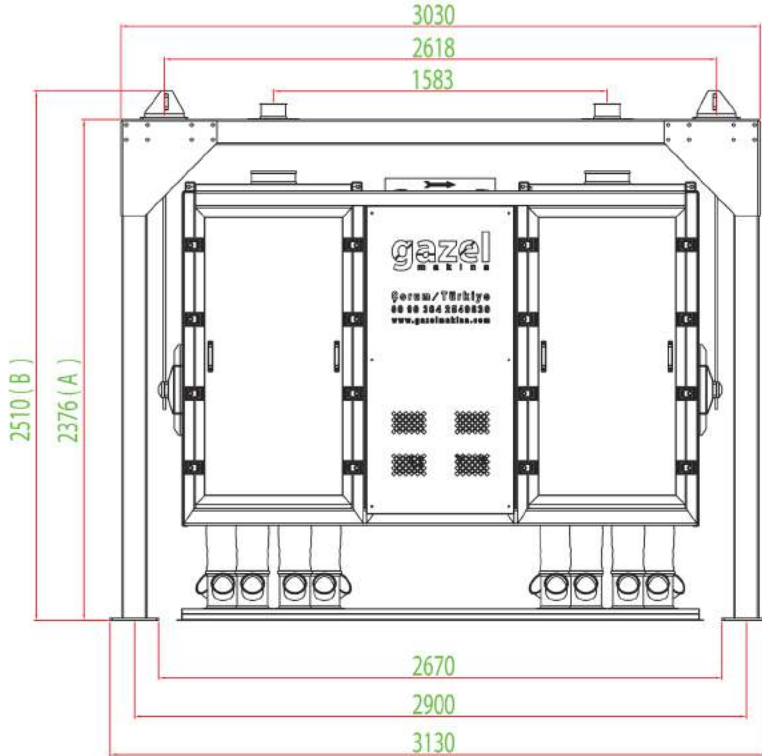
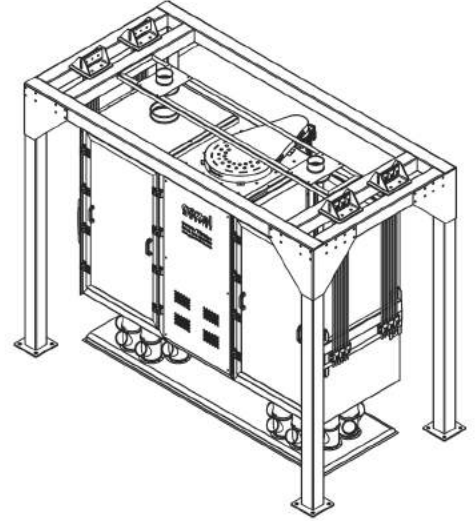
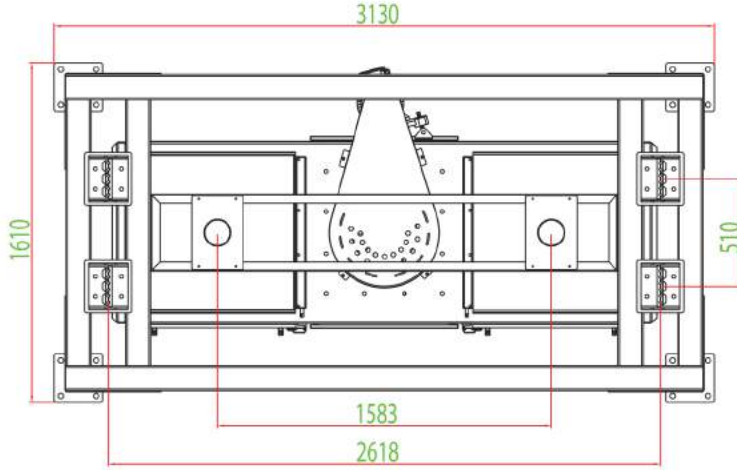

Tip Type	Pasaaj Sayısı Number of Section	Ölçüler Measures (mm)		Her Pasaajdaki Elek Sayısı Number of Sieves per Section	Toplam Kasa Yüksekliği Total Height of Sieves	Yaklaşık Eleme Alanı (m ²) Approximate Sifting Area (m ²)				Motor Devri Engine Speed (rpm)	Makine Devri Machine Speed (rpm)	Motor kw Engine kw	Makine Çalışma Dairesi Çapı Machine Working Circle Diameter (mm)	Yaklaşık Ağırlık Approximate Weight (KG)
		A	B			G TİP-W TYPE		N TİP-N TYPE						
						Max	Min	Max	Min					
GMS 2/24	2	2676	2810	24-20	169	23,16	19,30	19,30	16,08	1000	245	3	65	3200
GMS 2/20	2	2376	2510	20-16	139	19,30	15,44	16,08	12,86	1000	245	2,2	65	2800
GMS 2/16	2	2076	2210	16-12	109	15,44	11,58	12,86	9,65	1000	245	2,2	65	2350

EKİPMANLAR EQUIPMENT

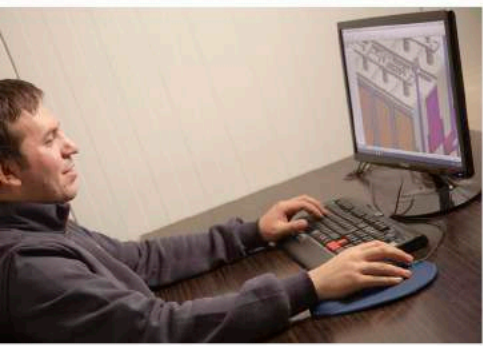

www.gazelmakina.com



SIİER

İşin özünden ilham aldık
teknolojiyle harmanladık.

We were inspired by the essence of the work,
and combined it with technology.

gazel
milling



KASALAR SIEVES

Plastik Kasa
Alüminyum Telöre
Plastic Sieve
Aluminum Frame

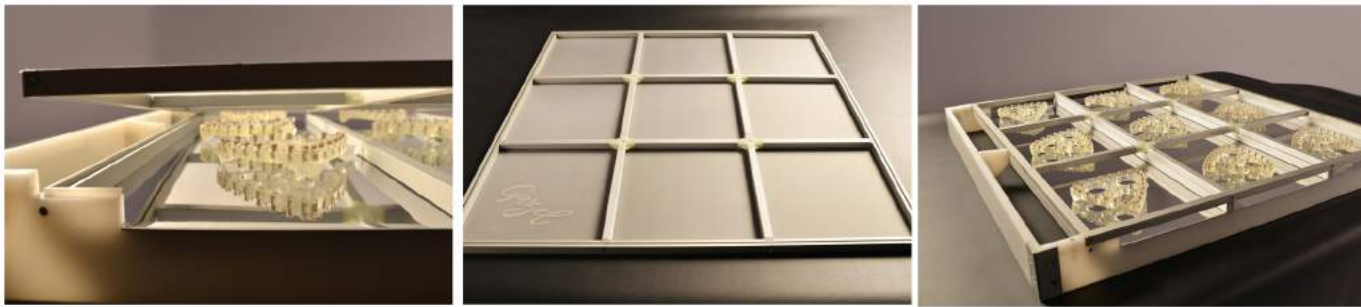

KASALAR SIEVES

Ahşap Kasa
Alüminyum Telöre
Wooden Sieve
Aluminum Frame

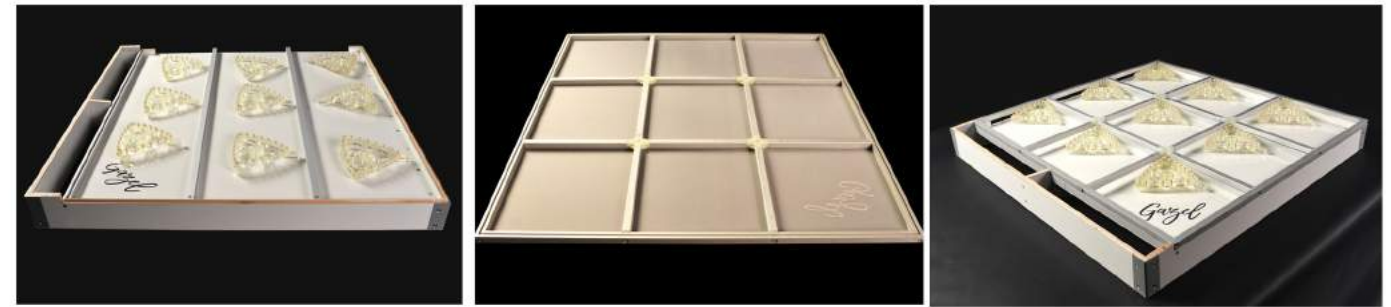

KASALAR SIEVES

Ahşap Kasa
Ahşap Telöre
Wooden Sieve
Wooden Frame

NEW
Patent
Pending

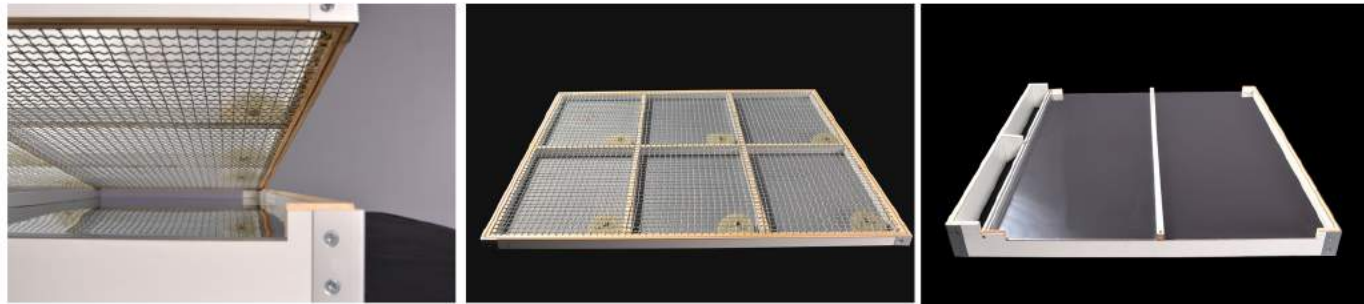

SIFTER

www.gazelmakina.com

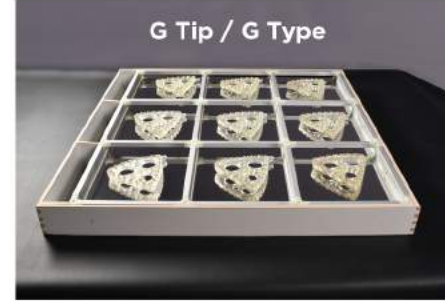

G Tip / G Type

Klasik Alüminyum Telörel Ahşap Kasa
Classic Wooden Sieve with Aluminum Frame

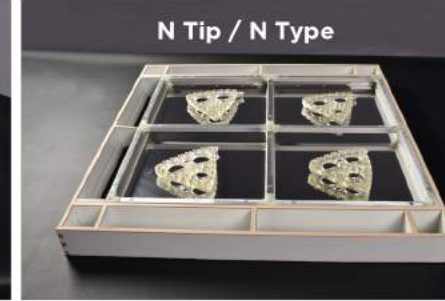

N Tip / N Type

Klasik Alüminyum Telörel Ahşap Kasa
Classic Wooden Sieve with Aluminum Frame



GMA 1000

Ahşap Telörel Ahşap Kasa
Wooden Sieve with Wooden Frame



Ahşap Telörel Ters Kasa
Wooden Reverse Sieve with Wooden Frame



Ahşap Telörel Ahşap Kasa
Wooden Sieve with Wooden Frame

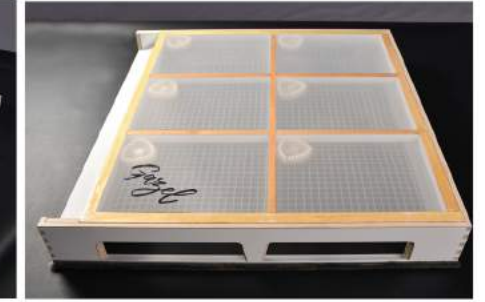

Ahşap Telörel TKD Kasa
Wooden TKD Sieve with Wooden Frame



Ahşap Telörel Taban Kasası
Wooden Bottom Sieve with Wooden Frame



Rampalı Kasa
Sieve with Sloping Pan



Kıl Fitol
Hair Wick



Özel Üst Baskı
Special Top Sieve



Taban Kasası
Bottom Sieve



Alüminyum Kapak
Aluminum Door



Kauçuk Kapak
Rubber Cover



Anahtar Seti
Set of Wrenches



Elek Alt-Üst Torbası
Sifter Top-Bottom Bag



Kontrol Borusu
Inspection Pipe



Elek Üst Girişi
Sifter Top Entry



Üst Baskı
Top Press



Elek Alt Tablası
Sifter Bottom Table

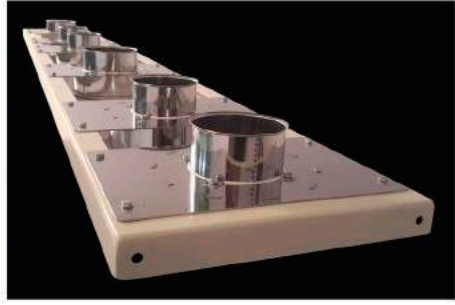

Elek Üst Tablası
Sifter Top Table



Kapak Kilit Sistemi
Cover Lock System

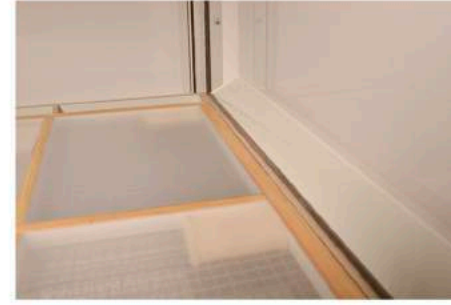

Yönlendirme Takozu
Guidance Part-One side

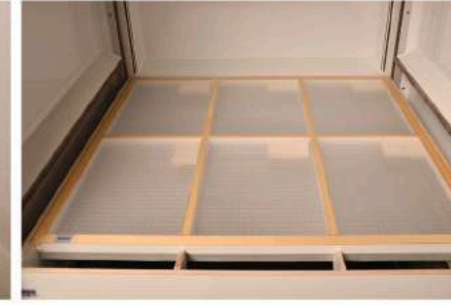

Yönlendirme Takozu
Guidance Part-Both sides

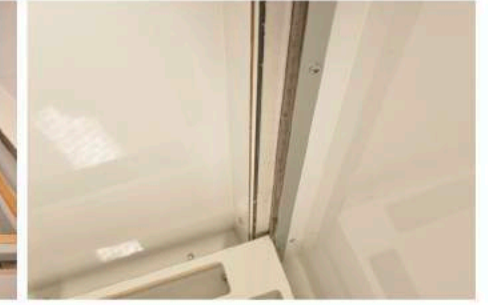

Kıl Fitilli Uygulaması
Hair Wick Application

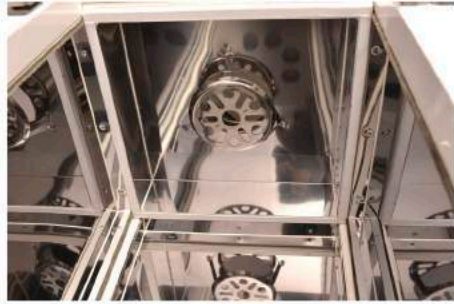

Krom Kaplama
Stainless Steel Covering



Kompakt Laminant Kaplama
Compact Laminate Covering



İpek
Sieve Cloth

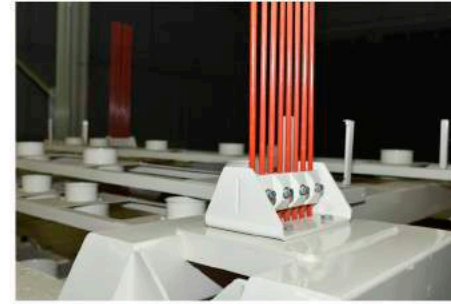

Elek Tavan Askılığı
Sifter Hanging Part

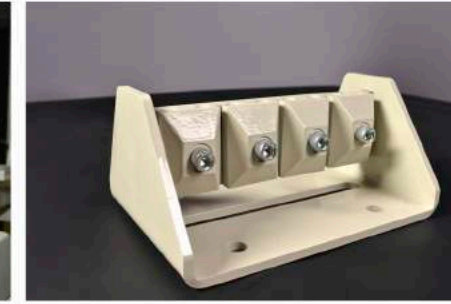

Elek Tavan Askılığı
Sifter Hanging Part

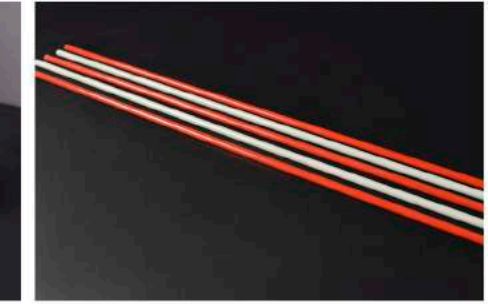

Askı Çubuğu
Hanging rod

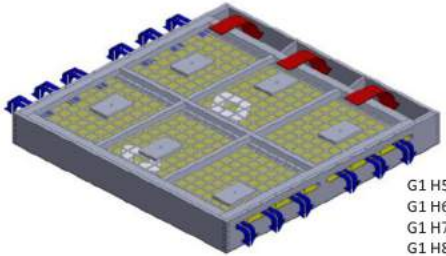
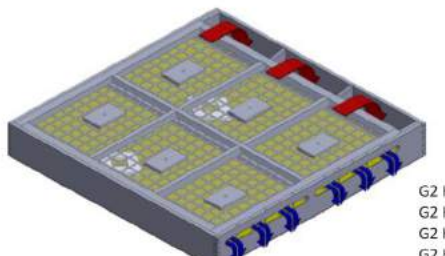
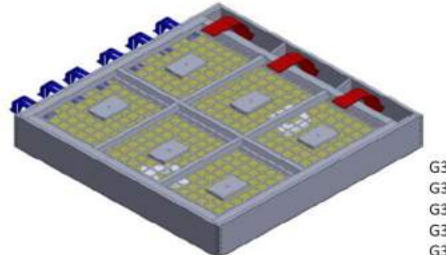
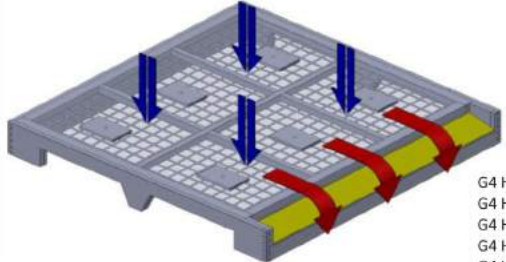
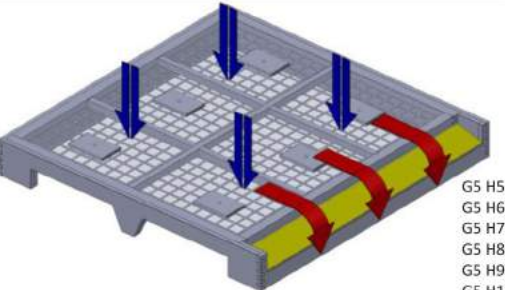
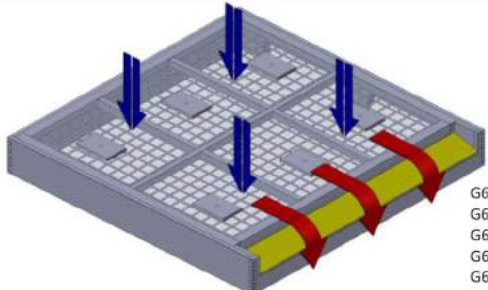
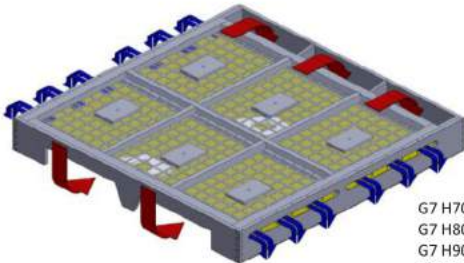
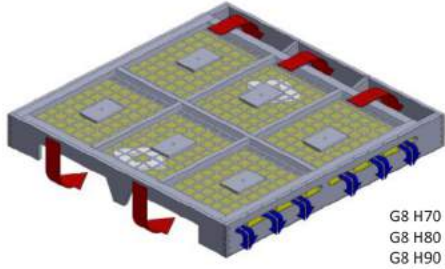
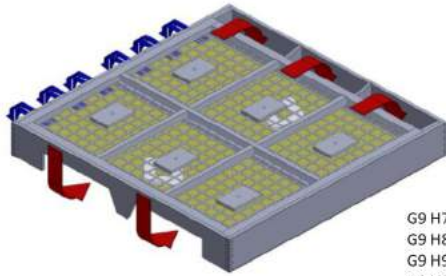
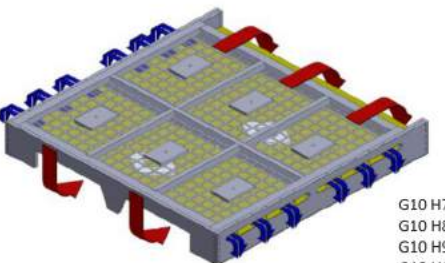

**KASA
TIPLERİ**

**TYPES
of SIEVE**

 G1 H55 MM G1 H60 MM G1 H70 MM G1 H80 MM G1 H90 MM G1 H100 MM G1 H110 MM	 G2 H55 MM G2 H60 MM G2 H70 MM G2 H80 MM G2 H90 MM G2 H100 MM G2 H110 MM
 G3 H55 MM G3 H60 MM G3 H70 MM G3 H80 MM G3 H90 MM G3 H100 MM G3 H110 MM	 G4 H55 MM G4 H60 MM G4 H70 MM G4 H80 MM G4 H90 MM G4 H100 MM G4 H110 MM
 G5 H55 MM G5 H60 MM G5 H70 MM G5 H80 MM G5 H90 MM G5 H100 MM G5 H110 MM	 G6 H55 MM G6 H60 MM G6 H70 MM G6 H80 MM G6 H90 MM G6 H100 MM G6 H110 MM
 G7 H70 MM G7 H80 MM G7 H90 MM G7 H100 MM G7 H110 MM	 G8 H70 MM G8 H80 MM G8 H90 MM G8 H100 MM G8 H110 MM
 G9 H70 MM G9 H80 MM G9 H90 MM G9 H100 MM G9 H110 MM	 G10 H70 MM G10 H80 MM G10 H90 MM G10 H100 MM G10 H110 MM

**KASA
TIPLERİ**

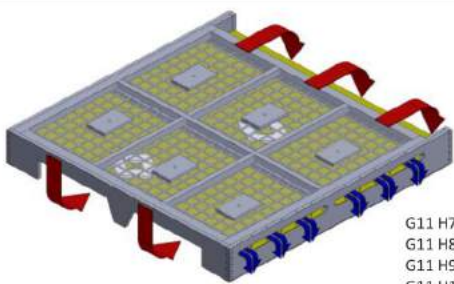
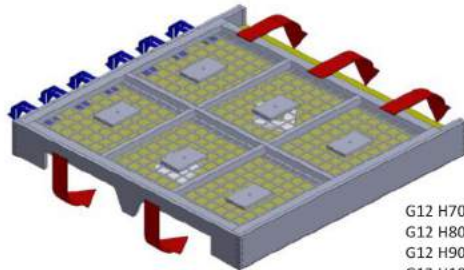
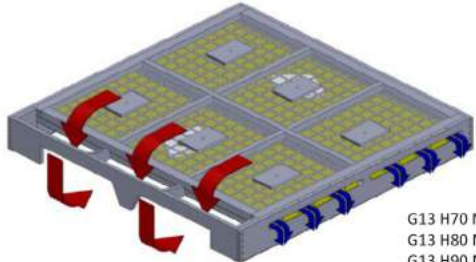
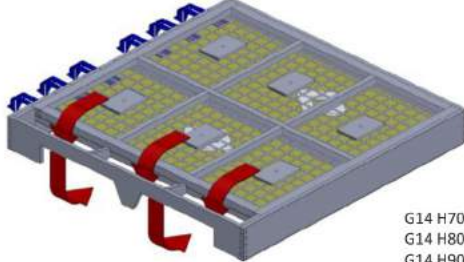
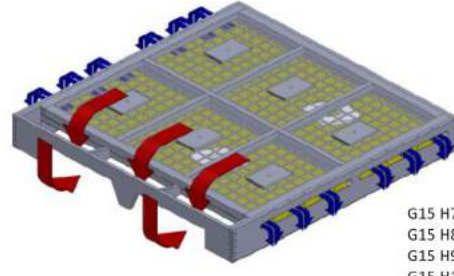
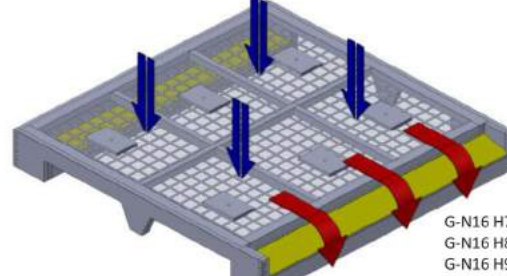
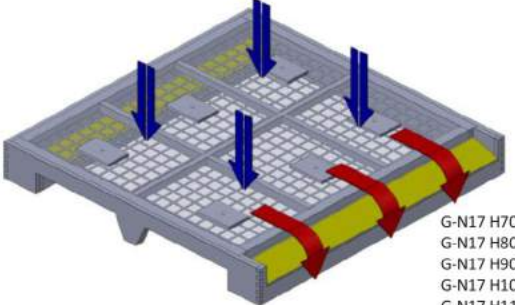
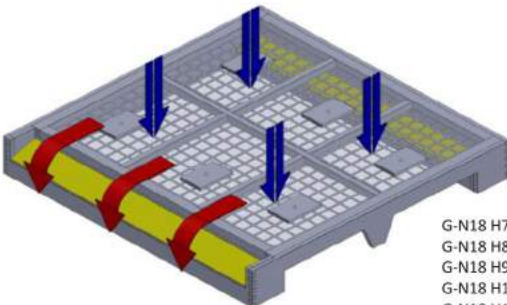
**TYPES
of SIEVE**

 G11 H70 MM G11 H80 MM G11 H90 MM G11 H100 MM G11 H110 MM	 G12 H70 MM G12 H80 MM G12 H90 MM G12 H100 MM G12 H110 MM
 G13 H70 MM G13 H80 MM G13 H90 MM G13 H100 MM G13 H110 MM	 G14 H70 MM G14 H80 MM G14 H90 MM G14 H100 MM G14 H110 MM
 G15 H70 MM G15 H80 MM G15 H90 MM G15 H100 MM G15 H110 MM	 G-N16 H70 MM G-N16 H80 MM G-N16 H90 MM G-N16 H100 MM G-N16 H110 MM
 G-N17 H70 MM G-N17 H80 MM G-N17 H90 MM G-N17 H100 MM G-N17 H110 MM	 G-N18 H70 MM G-N18 H80 MM G-N18 H90 MM G-N18 H100 MM G-N18 H110 MM
 GC1 H15 MM GC1 H20 MM GC1 H25 MM GC1 H30 MM GC1 H40 MM	

KASA TIPLERİ

TYPES of SIEVE

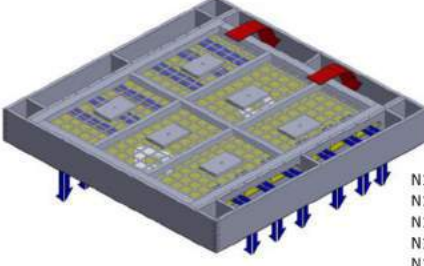
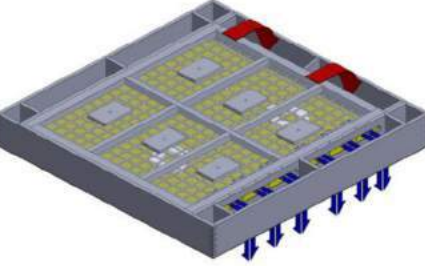
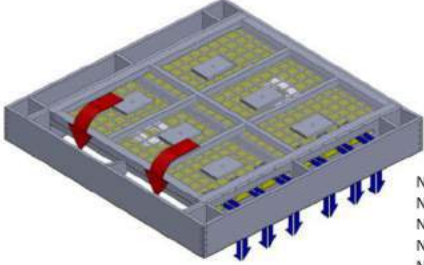
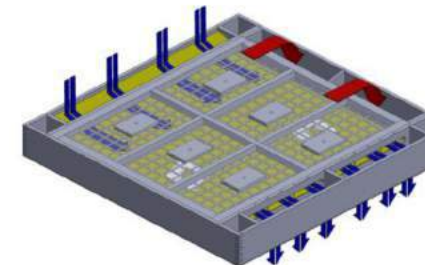
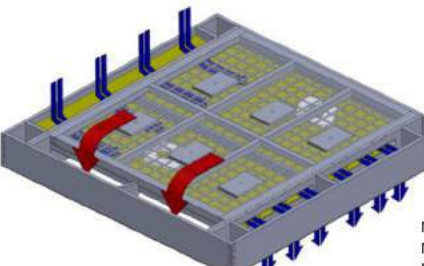
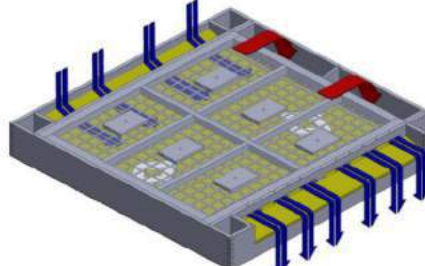
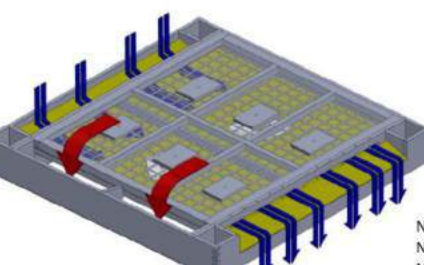
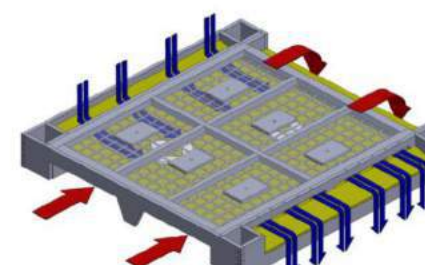
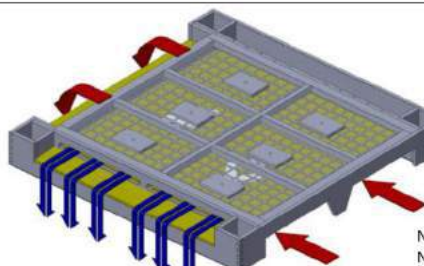
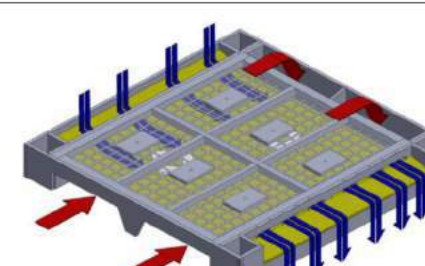
 <p>N1 H55 MM N1 H60 MM N1 H70 MM N1 H80 MM N1 H90 MM N1 H100 MM N1 H110 MM</p>	 <p>N2 H55 MM N2 H60 MM N2 H70 MM N2 H80 MM N2 H90 MM N2 H100 MM N2 H110 MM</p>
 <p>N3 H55 MM N3 H60 MM N3 H70 MM N3 H80 MM N3 H90 MM N3 H100 MM N3 H110 MM</p>	 <p>N4 H55 MM N4 H60 MM N4 H70 MM N4 H80 MM N4 H90 MM N4 H100 MM N4 H110 MM</p>
 <p>N5 H55 MM N5 H60 MM N5 H70 MM N5 H80 MM N5 H90 MM</p>	 <p>N6 H55 MM N6 H60 MM N6 H70 MM N6 H80 MM N6 H90 MM</p>
 <p>N7 H55 MM N7 H60 MM N7 H70 MM N7 H80 MM N7 H90 MM</p>	 <p>N8 H70 MM N8 H80 MM N8 H90 MM N8 H110 MM</p>
 <p>N9 H70 MM N9 H80 MM N9 H90 MM N9 H110 MM</p>	 <p>N10 H70 MM N10 H80 MM N10 H90 MM N10 H110 MM</p>

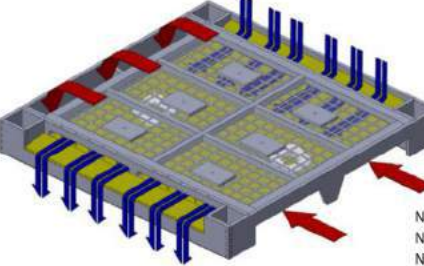
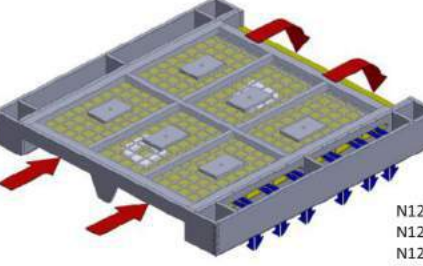
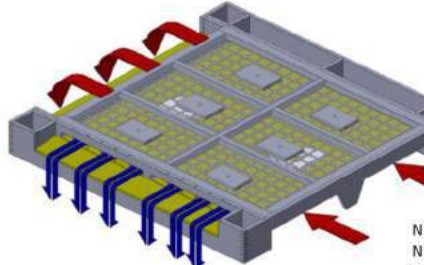
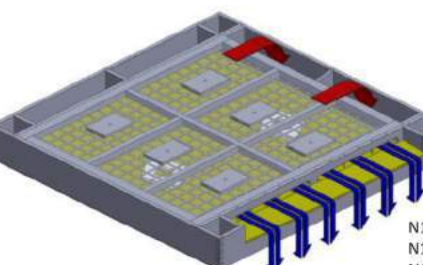
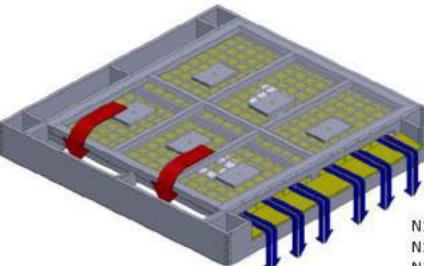
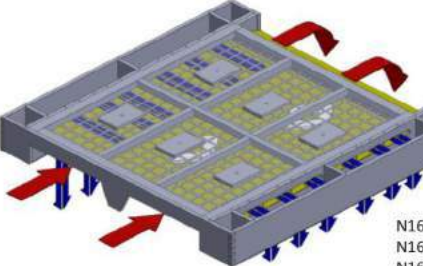
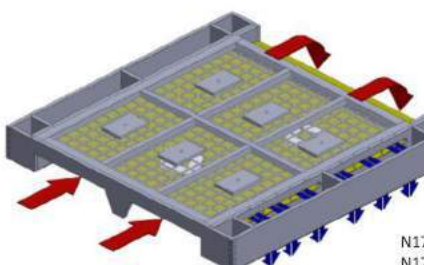
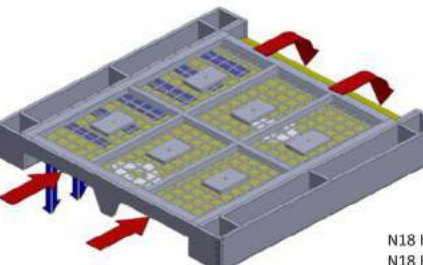
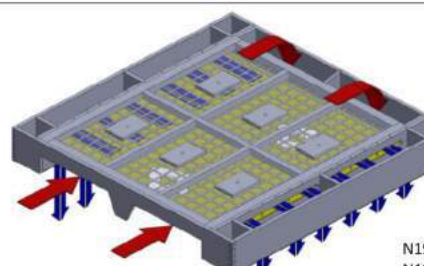
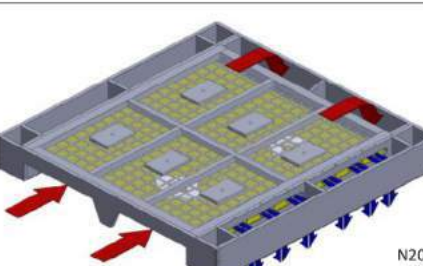

KASA TIPLERİ

TYPES of SIEVE

 <p>N11 H70 MM N11 H80 MM N11 H90 MM N11 H110 MM</p>	 <p>N12 H70 MM N12 H80 MM N12 H90 MM N12 H110 MM</p>
 <p>N13 H70 MM N13 H80 MM N13 H90 MM N13 H110 MM</p>	 <p>N14 H55 MM N14 H60 MM N14 H70 MM N14 H80 MM N14 H90 MM</p>
 <p>N15 H55 MM N15 H60 MM N15 H70 MM N15 H80 MM N15 H90 MM</p>	 <p>N16 H70 MM N16 H80 MM N16 H90 MM N16 H110 MM</p>
 <p>N17 H70 MM N17 H80 MM N17 H90 MM N17 H110 MM</p>	 <p>N18 H70 MM N18 H80 MM N18 H90 MM N18 H110 MM</p>
 <p>N19 H70 MM N19 H80 MM N19 H90 MM N19 H110 MM</p>	 <p>N20 H70 MM N20 H80 MM N20 H90 MM N20 H110 MM</p>

KASA TIPLERİ

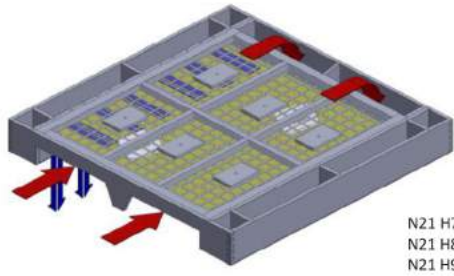
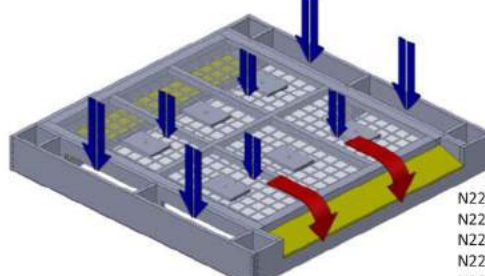
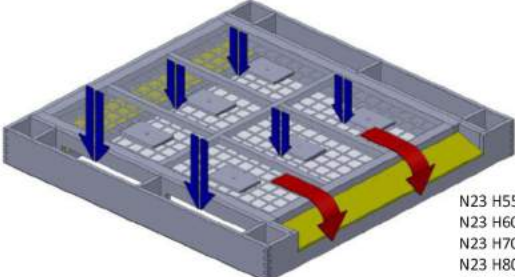
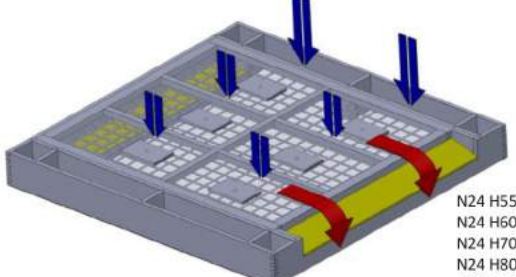
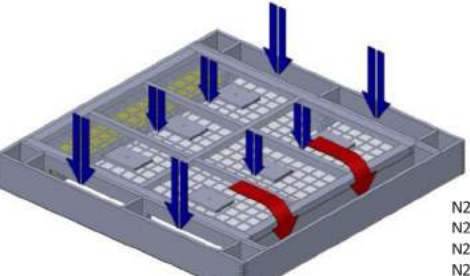
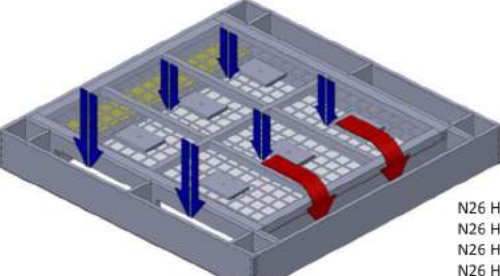
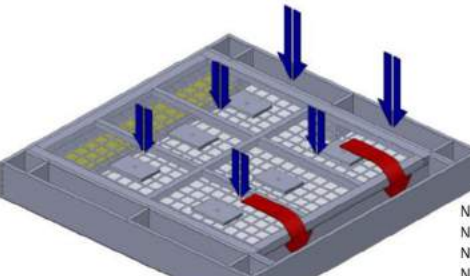
TYPES of SIEVE

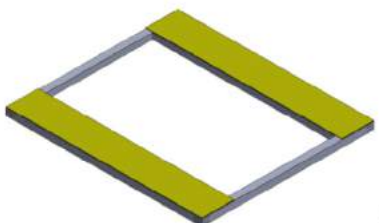
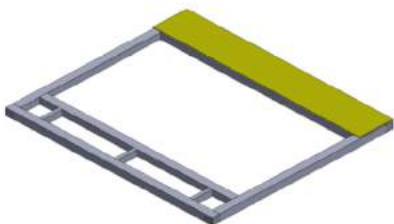
 <p>N21 H70 MM N21 H80 MM N21 H90 MM N21 H110 MM</p>	 <p>N22 H55 MM N22 H60 MM N22 H70 MM N22 H80 MM N22 H90 MM N22 H110 MM</p>
 <p>N23 H55 MM N23 H60 MM N23 H70 MM N23 H80 MM N23 H90 MM N23 H110 MM</p>	 <p>N24 H55 MM N24 H60 MM N24 H70 MM N24 H80 MM N24 H90 MM N24 H110 MM</p>
 <p>N25 H55 MM N25 H60 MM N25 H70 MM N25 H80 MM N25 H90 MM N25 H110 MM</p>	 <p>N26 H55 MM N26 H60 MM N26 H70 MM N26 H80 MM N26 H90 MM N26 H110 MM</p>
 <p>N27 H55 MM N27 H60 MM N27 H70 MM N27 H80 MM N27 H90 MM N27 H110 MM</p>	 <p>NC1 H15 MM NC1 H20 MM NC1 H30 MM NC1 H40 MM</p>
 <p>NC2 H15 MM NC2 H20 MM NC2 H30 MM NC2 H40 MM</p>	 <p>NC2 H15 MM NC2 H20 MM NC2 H30 MM NC2 H40 MM</p>

GALERİ

GALLERY



